

TC73

Portable Pipe Beveling Machine

Range Øe 10-73 mm (0.39"-2.87")



TC pipe beveler with OD locking system in line with cutter head.
Different sizes of locking jaw available according to tube size.

RANGE:
10 - 73mm Ø.

FUNCTIONS :
BEVELLING/FACING
COUNTERBORING

MATERIALS :
ANY KIND OF STEEL

POWER :
PNEUMATIC/ELECTRIC

NOTE :
DEVELOPE FOR BEVELLING
MEMBRANE WALL PANELS IN SPOT
OF 60MM, SOLID BARS AND ALL
WORKING CONDITIONS WHICH DO
NOT ALLOW D CLAMPING

TC E



The motor can be mounted 90° or in line to suit working conditions.

Electric version available or a conversion kit to easily change pneumatic to electric

EXAMPLES OF CUTTER BITS

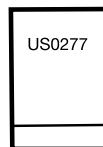
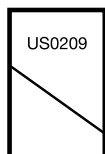
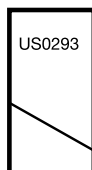

TC73

TECHNICAL FEATURES

		TC	TC E
Locking range	mm \varnothing o/d.)	10-73	10-73
Idle speed	Rpm	110	75
Torque	Nm	56	82
Feeding stroke	mm	30	30
Pneumatic motor power	Hp (W)	0,70 (510)	-
Air consumption	cfm	34-36	-
Air pressure	psi	90	-
Air hose connection	inches	1/2"	-
Electric motor power	Watt	-	750
Voltage	Volt	-	110/220
Frequency (cycles)	Hz	-	50
Max noise level	dB	75	75
Unit weight	Kg	12,0	13,0

OPTIONAL



50MM DIACUTTER HEAD AVAILABLE
FOR TIGHT SPOTS

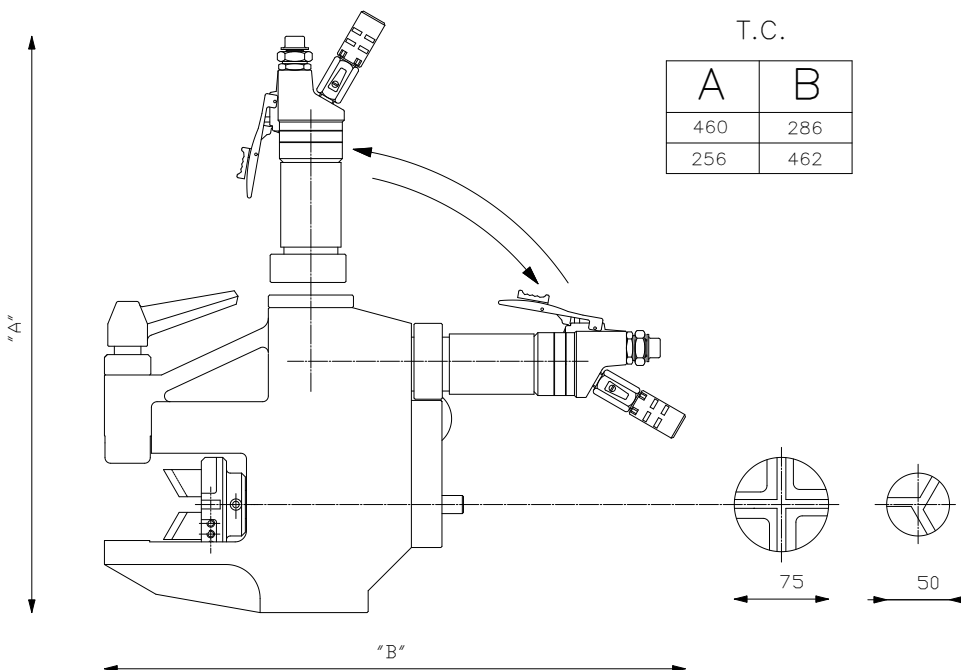

All units are supplied complete with all gripping segments to cover the full range of the machine.
Service tools, drawings, instruction manual and warranty certificate are also supplied as standard. Each machine is supplied with a protective carrying case.
We strongly recommend the use of the GBC portable filter lubricator with all our pneumatic models.