

# Compact Edge

Range w.t. 6-60 mm (1/4" - 2 3/8")

Brand new plate beveling machine **Compact EDGE**, featuring a high speed face mill with interchangeable inserts, with reduced structural dimensions and weight for a more flexible and dynamic use.



plate detecting sensor



feeding system



dual amortization system



chips conveyance system

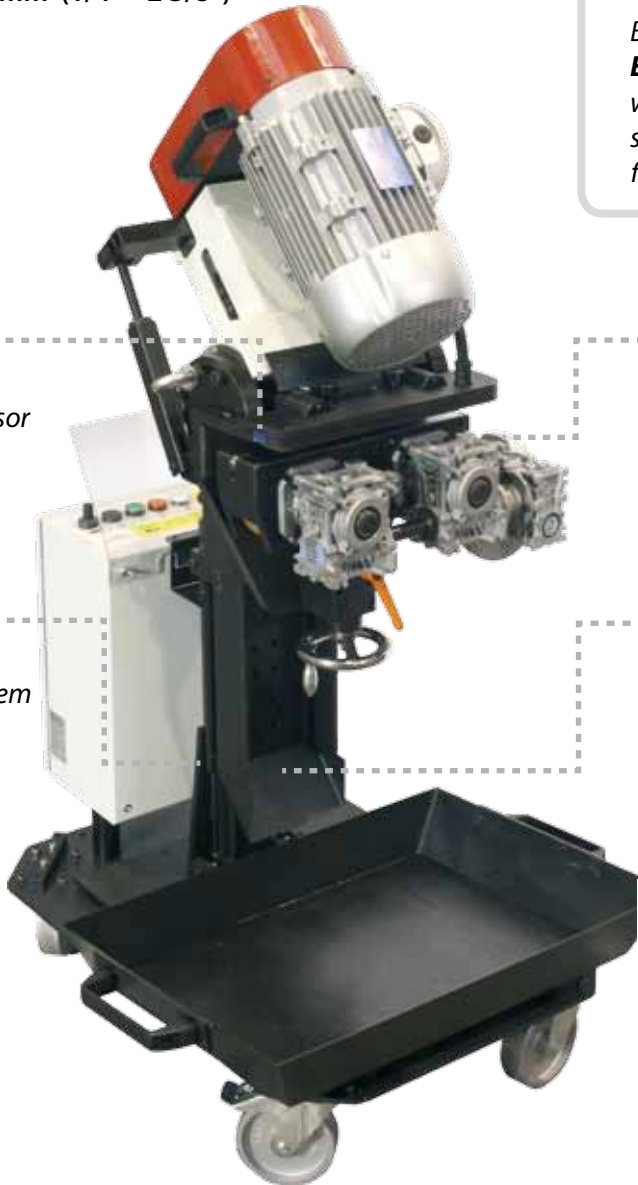

STANDARD

SPECIAL



Thanks to its new design the unit can be used in two different configurations:

- standard: the machine is used with the trolley
- special : the head of the machine is detached from the trolley and directly applied on the edge of the plate

# Compact Edge

## - TECHNICAL FEATURES

### compact EDGE

### compact EDGE $\mathbf{\Psi}$ reverse

std. voltage	volt/hz/phase	400 / 50 / 3	400 / 50 / 3
adjustable beveling speed	m/min	0 - 1.6	0 - 1.6
	surface feet/min	0 - 5.25	0 - 5.25
electric motor power	kw	3	3
plate thickness	mm	6 - 60	6 - 60
	inch	1/4" - 2 3/8"	1/4" - 2 3/8"
std bevel angle	deg	15° - 60°	15° - 60°
face mill speed without speed regulator	rpm	800	800
face mill speed with speed regulator	rpm	min 300 - max 800	min 300 - max 800
9 inserts face mill ( $\varnothing$ )	mm	80	80
	inches	3.15"	3.15"
machine gross weight	kg	210	210
	lb	462,97	462,97
machine head weight without trolley	kg	143	143
	lb	315,26	315,26
trolley weight	kg	67	67
	lb	147,70	147,70

\*Different voltage available on request

BEVEL ANGLE "a"	MAX PLATE W.T. "S"	MAX BEVEL PERFORMANCE*	
		"L"max	"P"max
15°	60 mm	40 mm	38,7 mm
22,5°	60 mm	40 mm	37,0 mm
30°	60 mm	40 mm	34,7 mm
37°31'	60 mm	40 mm	31,7 mm
45°	60 mm	40 mm	28,3 mm
55°	60 mm	40 mm <td 23,0 mm	
60°	60 mm	40 mm	20,0 mm

\*In più passate  
\*In multiple steps

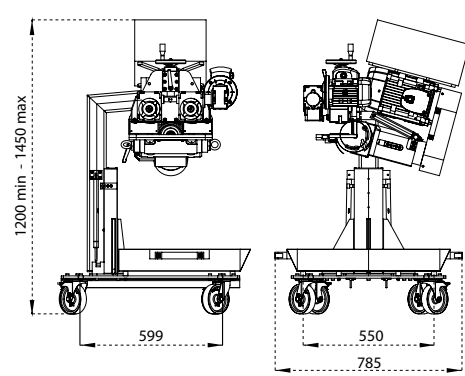
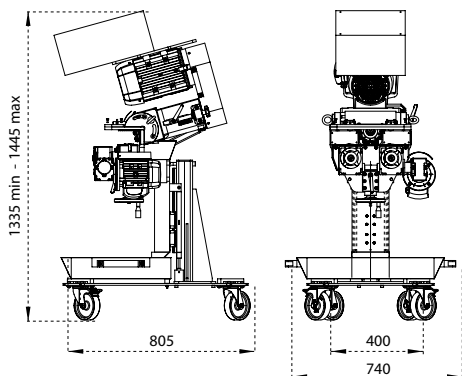
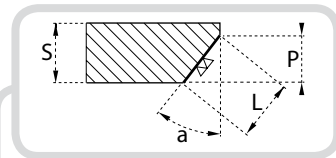
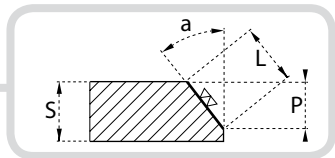

COMPACT EDGE

COMPACT EDGE  $\mathbf{\Psi}$ reverse