

## SB500

Range 100 - 508 mm (4" - 20")



*Semi-automatic unit structurally strong and at the same time user friendly. The locking vice design enables the automatic centring and positioning without causing deformation to the pipe.*

*The on board control panel enables to adjust the chuck speed and feeding as well as the feeding of the mobile head and the activation of the refrigerating liquid pump.*

*The SB500 can be equipped with easily interchangeable tools, both HSS type and insert type.*

- Vice designed for automatic centring without deformation;
- On board control panel;
- Chuck feeding adjustment;
- Mobile head feeding adjustment;
- Chuck speed adjustment;
- Cooling liquid recycling pump;
- Interchangeable tooling with Supermaxi 7\_24 and Hypermaxi 20\_36.

### - DIMENSIONS

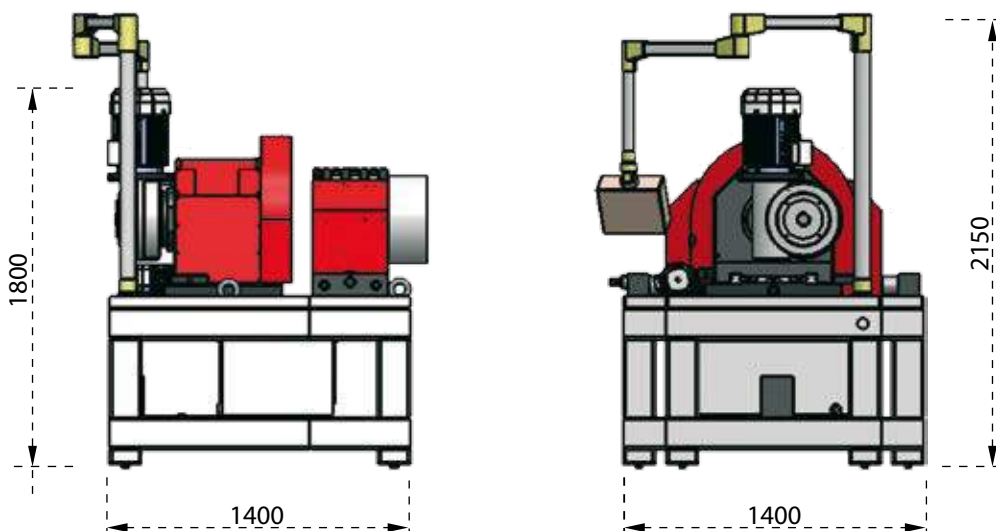

# SB500

## - TECHNICAL FEATURES

Locking range	mm in	100 -508 4" - 20"
Pipe thickness	mm	25
Idle Speed	giri/min	0 ÷ 28
Electric motor power	Hp(W)	9500
Tension	V	400
Power	kW	10
Frequency	Hz	50/60
Max Acoustic Emissions	db	75
Weight	kg	2350

*\*Different voltage available on request*

