



Spec Master HPM6040 Series

6.0 Purity Two Stage Nickel Plated Brass Barstock Diaphragm Manual Change Gas Control Panel



The Spec Master HPM6040 Series Two Stage twin cylinder manual change control panels are designed for primary pressure gas control of non-corrosive or toxic, high purity gases up to grade 6.0 purity (99.9999%), on gas distribution systems where constant delivery pressure is required.

- **HPM6041** Series | Two Stage Twin Cylinder Diaphragm Manual Gas Change Control Panel, FKM Seal, FFKM Pressure Relief Valve
- **HPM6042** Series | Two Stage Twin Cylinder Diaphragm Manual Gas Change Control Panel, EPDM Seal, FFKM Pressure Relief Valve

★ FEATURES

- High pressure isolation valves
- High pressure purge facility
- Two Stage pressure regulation
- Process line isolation valve
- Encapsulated valve design
- Twin cylinder configuration

📦 MATERIAL

■ Body	Nickel Plated Brass Barstock
■ Bonnet	Nickel Plated Brass Barstock
■ Diaphragm	316L Stainless Steel
■ Bonnet Seal	PTFE
■ Seal Option	FKM / EPDM
■ Valve Seat	PCTFE
■ Filter	10 Micron 316L Stainless Steel

👍 SPECIFICATION

■ Maximum Inlet Pressure	15 bar (220 PSI) 60 bar (870 PSI) 300 bar (4350 PSI) *
■ Delivery Pressure Range	3.5 bar (50 PSI) 6.0 bar (90 PSI) 10 bar (150 PSI)
■ Gauges	50mm (2") Diameter
■ Ports	1/4" NPT Female
■ Temperature Range	-20° C to +60° C (-4° F to +140° F)
■ Helium Leak Integrity	1x10 ⁻⁹ mbar l/s
■ Weight	5.0 kg (11.02 lbs) ****

* Subject to cylinder connection – **** Subject to final configuration

✓ FLOW PERFORMANCE

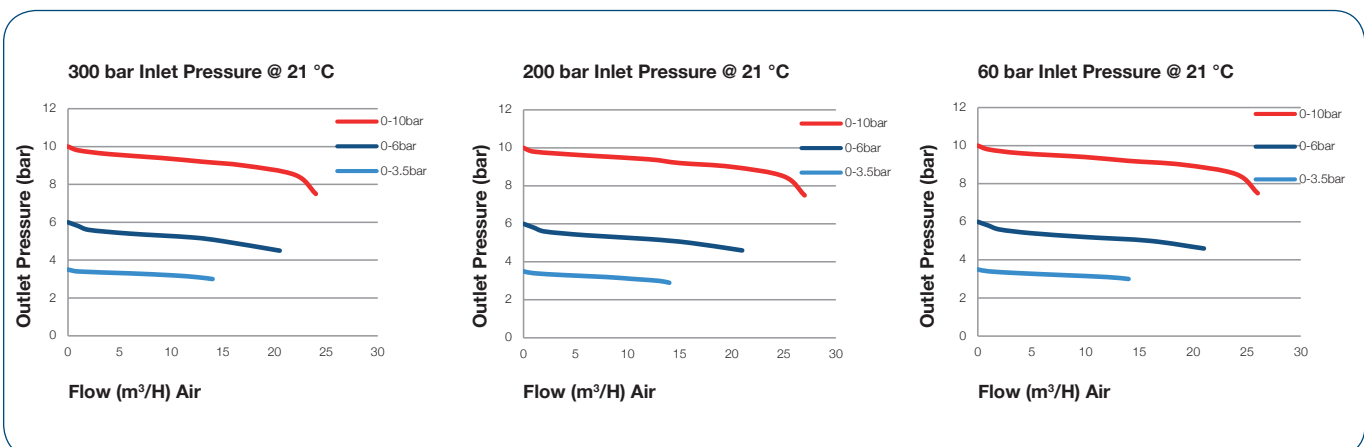

DRAWINGS

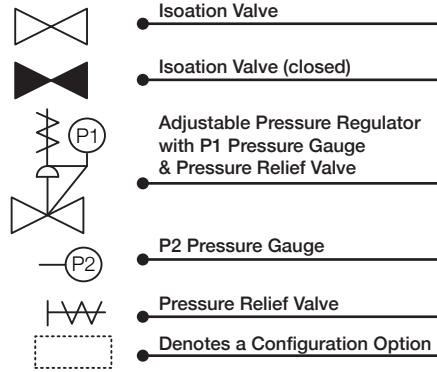
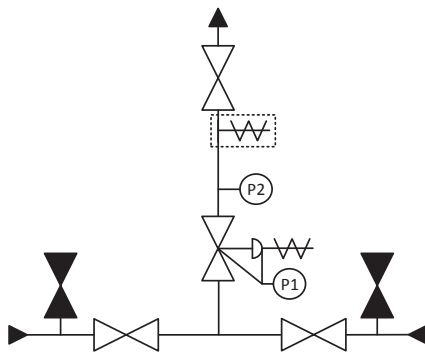
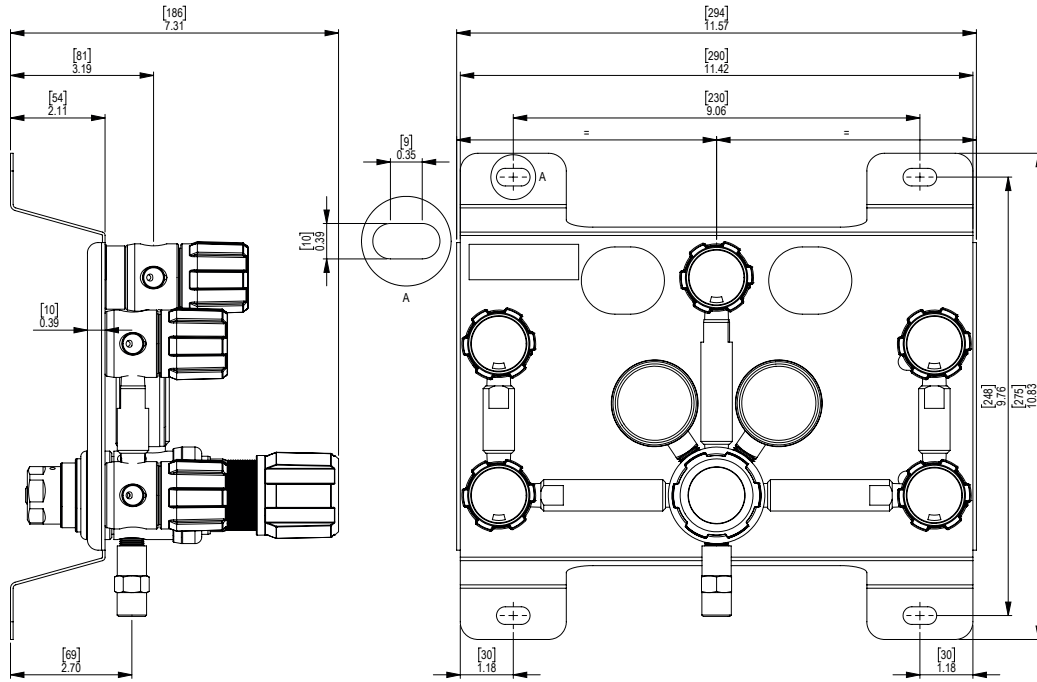

MODEL NO. SELECTOR GUIDE

Example for a Model No. for HPM6040 Series

HPM6041- 02- 03- 00- 00- 000- 00- A

Product Type	Inlet Pressure Bar [PSI]	Outlet Pressure Bar [PSI]	Inlet Pressure Gauge	Outlet Pressure Gauge	Inlet/Cylinder Connection	Outlet Connection	Options
HPM6041	02 60 [870]	03 0 to 3.5 [50]	00 No Gauge Fitted	00 No Gauge Fitted	000 1/4 NPT Female	00 1/4 NPT Female	A No Options Selected
HPM6042	04 300 [4350]	04 0 to 6 [90]	01 bar/PSI	01 bar/PSI	001 1/8 Stainless Steel Compression	01 1/8 Stainless Steel Compression	F Bonnet Vent Capture Kit
					002 1/4 Stainless Steel Compression	02 1/4 Stainless Steel Compression	G Helium Test Certificate
	06 15 [220]	05 0 to 10 [150]	02 bar/PSI Contact Gauge		003 6mm Stainless Steel Compression	03 6mm Stainless Steel Compression	K Certificate of Conformity
					004 1/4 NPT Male	04 1/4 NPT Male	M CO2 Burst Disc
					007 G3/8 BSP R/H Brass Male	07 G3/8 BSP R/H, Brass, Male	P Calibration/ Pressure Test Certificate
					008 G3/8 BSP L/H Brass Male	08 G3/8 BSP L/H, Brass, Male	R Fitted Pipeline Pressure Relief Valve
							X Special Instruction