

GUIDE TO MMA WELDING



 **JASIC**

The power in inverter technology



 **WILKINSON STAR**
wilkinsonstar.com



This guide is designed to provide helpful information relating to the electric arc welding and cutting process.

The guide is split into specific areas of welding and cutting and designed to give an understanding of these areas.

The guide is not designed to be a comprehensive text book and the concept is to convey knowledge and techniques by theory and practical methods.

It should be understood that methods may not be the "only way to do it" but represent many current practices and systems.

The guides are constantly reviewed to incorporate any changes in procedures, technologies and equipment.

Wilkinson Star Limited own full copyright in respect of this manual and its reproduction.

No part of this manual may be reproduced by any means photocopy, electronic, mechanical or otherwise without the prior written permission of Wilkinson Star Limited.



E & O. E. Wilkinson Star Ltd 2017

What is Welding?	4
General Safety Instructions	8
What is the MMA process?	12
What Makes Up the MMA Unit?	15
The Electrode	17
Electrode Storage	20
Electrode Selection	21
Welding Fume	23
Controls Used in MMA	24
MMA Process Features & Benefits	25
Welding Joint Form	26
Electrode Positioning	27
MMA Welding Problems	29

NOTES

A series of horizontal dashed lines for writing notes.



What is Welding?

Welding is the process of joining together two or more pieces using heat and/or pressure to form a high strength joint. There are many ways to perform a weld and these require different skill levels and can utilise many levels of technology in the equipment used.

To carry out a weld a heat source is required.

This can be thermo chemical energy which is produced using a combination of gases such as oxygen and acetylene to produce a flame. This process was widely used but requires a high level of manual skill and dexterity. Another source is electrical energy. This is where an arc is established between the electrical source or Arc welding power source and the work piece. This process is referred to as Arc welding or Arc cutting and can produce heat at temperatures from 3000°C to 20,000°C. Arc welding can be used on a wide range of different metals, alloys and materials. Dependent on the process and welding result required Arc welding requires different skill and dexterity levels. Arc welding uses a wide range of power source types from basic transformers to equipment which utilises high levels of technology.

The applications which utilise Arc welding are extensive, from DIY to nuclear, structural fabrication to aerospace, vehicle repair to vehicle assembly, robot automation to offshore the list is endless. Welding can be carried out pretty much anywhere...

The Arc welding and cutting processes covered:

- Manual metal arc
- MIG (Metal inert gas) process
- MAG (Metal active gas) process
- FCW (Flux cored welding) process
- TIG (Tungsten inert gas) process
- Plasma arc cutting process
- Resistance welding

The individual process information will be given in the related units. In addition to the above processes there are others such as laser, submerged arc, ultrasound and friction welding.

The materials welded?

The most commonly welded materials are aluminium, mild steel, stainless steel and their alloys. Also in today's rapidly changing world many plastics can also be welded.

Which process?

The welding process used is chosen based on the materials to be welded and the material thickness. Also to be taken into consideration is the production rate and visual aesthetics of the weld which may be on show.

Manual Arc (MMA)

This is one of the oldest processes and is still in common use. It is well suited to use welding outdoors and in repair work. It is a slow process however and requires a high skill level but can be used on a wide range of materials. It can also be used in confined areas as the electrodes can be bent into shape for access. Equipment costs are lower than the other processes.

Metal inert/active gas (MIG/MAG)

The process is a common, versatile welding process. It provides high deposition rates and is suited to a wide range of material thicknesses, thin to thick. Compared with Manual Arc welding the process provides a weld with minimal weld finishing as there is minimal spatter and no electrode slag. It requires a low - medium skill level and has less problems to achieve good quality compared to TIG/MMA it has a narrow heat affected area. Its disadvantage is the torch as it is subject to a number of wear components such as contact tips, nozzles, liners etc. It is often a process that is automated to provide even higher production rates.



Flux Cored Welding (FCW)

Flux cored welding is a type of MIG/MAG welding using a standard MIG/MAG power source but uses a consumable which may contain a core of constituents which allow the process to self-shield itself therefore requiring no additional gas shield supply. This makes it suitable for welding in areas where there may be draughts such as outdoors. In addition, consumables may contain elements to provide high deposition rates and hence productivity. The flux core however produces a slag coating which need to be cleaned after welding.

Tungsten Inert Gas (TIG)

TIG welding, is an arc welding process that uses a non-consumable tungsten electrode to produce the weld. The weld area and electrode is protected from oxidation or other atmospheric contamination by an inert shielding gas (argon or helium) and a filler metal is normally used, though some welds, known as autogenous welds do not require it. A constant-current welding power supply produces the electrical energy, which is conducted across the arc through a column of highly ionized gas. TIG offers a high quality weld although generally a slower process compared to the others which requires a higher skill level.

Plasma Cutting

The basic principle is that the arc formed between the electrode and the work piece is constricted by a fine bore nozzle.

This constriction increases the temperature and velocity of the plasma emanating from the nozzle.

The temperature of the plasma arc is in excess of 20,000°C and the velocity can approach the speed of sound. When used for cutting, the plasma gas flow is high and creates a deeply penetrating high temperature plasma jet there by cutting through the material.

The force of the arc blows away any molten material in the form of dross.

The plasma process operates by using the high temperature arc to melt the metal. The plasma process can therefore be used to cut metals including cutting metals which form refractory oxides such as stainless steel, aluminium, cast iron and non-ferrous alloys. The cut quality is dependent on many parameters but the system is easy to use and often is the only practical or cost effective solution.



What is Welding?

Resistance Welding (Spot)

Resistance welding (Spot) is also one of the oldest of the electric welding processes in use in the welding industry today. The weld is made by a combination of heat, pressure and time. It is the resistance of the material to be welded to current flow that creates a localised heating in the material to be welded and hence the name resistance welding.

The resistance of different materials will create different levels of heat for the same current passing through it.

The pressure exerted by the electrode arms and electrode tips through which the current flows, holds the parts to be welded in intimate contact before, during and after the welding current time cycle. The required amount of time current flows in the joint is determined by material thickness and type, the amount of current flowing and the cross-sectional area of the welding tip contact surfaces.



Industry examples that use welding and cutting processes.



Process Comparison

	TIG WELDING	MMA WELDING	MIG WELDING
Skill level required	High	High – Especially for high quality and non ferrous material	Low - Medium
Quality	Requires high skills for good quality	Requires high skills for good quality	Less problems to achieve good quality compared to TIG/MMA
Distortion/heat input	High	High	Low-narrow heat affected area
Ease of mechanisation	Some difficult positions	Difficult	Simple
Equipment maintenance	Needs training	Needs basic training	Needs training
Consumable parts	Negligible	Negligible	Torch components such as contact tips, nozzles, liners etc.

Equipment must only be used for the purpose it was designed for. Using it in any other way could result in damage or injury and in breach of the safety rules. Only suitably trained and competent persons should use the equipment. Operators should respect the safety of other persons.

PPE and workplace safety equipment must be compatible for the application of work involved

Use of personal protective equipment (PPE)

Welding arc rays from all the welding processes produce intense, visible and invisible (ultraviolet and infrared) rays that can burn eyes and skin.

- Wear an approved welding helmet fitted with an appropriate shade of filter lens to protect your face and eyes when welding or watching.
- Wear approved safety glasses with side shields under your helmet.
- Never use broken or faulty welding helmets.
- Always ensure there are adequate protective screens or barriers to protect others from flash, glare and sparks from the welding area.
- Ensure that there are adequate warnings that welding or cutting is taking place.
- Wear suitable protective flame resistant clothing, gloves and footwear.
- Check and be sure the area is safe and clear of inflammable material before carrying out any welding.



Some welding and cutting operations may produce noise. Wear safety ear protection to protect your hearing if the ambient noise level exceeds the allowable limit (e.g: 85 dB).

CURRENT	MMA ELECTRODES	MIG LIGHT ALLOYS	MIG HEAVY METALS	MAG	TIG ON ALL METALS	PLASMA CUTTING	PLASMA WELDING	GOUGING ARC/AIR
10	8							
15					9		10	
20								
30	9	10	10	10	10			
40						11	11	
60	10							10
80						11		
100				11			12	
125								
150	11	11	11	12	12			
175								
200							13	
225		12			13	12		11
250	12		12	13				12
275								
300		13						13
350								
400	13	14	13	14	14	13	14	
450								14
500	14	15	14	15				15

Safety against fumes and welding gases

Locate the equipment in a well-ventilated position. Keep your head out of the fumes. Do not breathe the fumes. Ensure the welding zone is in a well-ventilated area.

If this is not possible provision should be made for suitable fume extraction. If ventilation is poor, wear an approved respirator.

Read and understand the Material Safety Data Sheets (MSDS's) and the manufacturer's instructions

for metals, consumable, coatings, cleaners and de-greasers. Do not weld in locations near any de-greasing, cleaning or spraying operations. Be aware that heat and rays of the arc can react with vapours to form highly toxic and irritating gases.



An example of personal fume extraction

Precautions against fire and explosion

Avoid causing fires due to sparks and hot waste or molten metal.

Ensure that appropriate fire safety devices are available near the cutting/welding area.

Remove all flammable and combustible materials from the cutting/welding zone and surrounding areas. Do not cut/weld fuel and lubricant containers, even if empty. These must be carefully cleaned before they can be cut/welded.

Always allow the cut/welded material to cool before touching it or placing it in contact with combustible or flammable material.

Do not work in atmospheres with high concentrations of combustible fumes, flammable gases and dust.

Always check the work area half an hour after cutting to make sure that no fires have begun.

Take care to avoid accidental contact of electrode to metal objects.

This could cause arcs, explosion, overheating or fire.



Understand your fire extinguishers

General operating safety

Never carry the equipment or suspend it by the carrying strap or handles during welding.

Never pull or lift the machine by the welding torch or other cables. Always use the correct lift points or handles. Always use the transport under gear as recommended by the manufacturer.

Never lift a machine with the gas cylinder mounted on it.

If the operating environment is classified as dangerous, only use S-marked welding equipment with a safe idle voltage level. Such environments may be for example: humid, hot or restricted accessibility spaces.

Working environment

Ensure the machine is mounted in a safe and stable position allowing for cooling air circulation.

Do not operate equipment in an environment outside the laid down operating parameters.

The welding power source is not suitable for use in rain or snow.

Always store the machine in a clean, dry space.

Ensure the equipment is kept clean from dust build up.

Always use the machine in an upright position.

Protection from moving parts

When the machine is in operation keep away from moving parts such as motors and fans.

Moving parts, such as the fan, may cut fingers and hands and snag garments.

Protections and coverings may be removed for maintenance and controls only by qualified personnel after first disconnecting the power supply cable.

Replace the coverings and protections and close all doors when the intervention is finished and before starting the equipment.

Take care to avoid getting fingers trapped when loading and feeding wire during set up and operation.

When feeding wire be careful to avoid pointing it at other people or towards your body.

Always ensure machine covers and protective devices are in operation.

Risks due to magnetic fields

The magnetic fields created by high currents may affect the operation of pacemakers or electronically controlled medical equipment.

Wearers of vital electronic equipment should consult their physician before beginning any arc welding, cutting, gouging or spot welding operations.

Do not go near welding equipment with any sensitive electronic equipment as the magnetic fields may cause damage.

Keep the torch cable and work return cable as close to each other as possible throughout their length.

This can help minimise your exposure to harmful magnetic fields.

Do not wrap the cables around the body.

Handling of compressed gas cylinders and regulators

Always check the gas cylinder is the correct type for the welding to be carried out.

All cylinders and pressure regulators used in welding operations should be handled with care.

Never allow the electrode, electrode holder or any other electrically "hot" parts to touch a cylinder.

Keep your head and face away from the cylinder valve outlet when opening the cylinder valve.

Always secure the cylinder safely and never move with regulator and hoses connected.

Always check for leaks.

Never deface or alter any cylinder

General electrical safety

The equipment should be installed by a qualified person and in accordance with current standards in operation. It is the users responsibility to ensure that the equipment is connected to a suitable power supply. Consult with your utility supplier if required. Do not use the equipment with the covers removed. Do not touch live electrical parts or parts which are electrically charged. Turn off all equipment when not in use.



In the case of abnormal behaviour of the equipment, the equipment should be checked by a suitably qualified service engineer.

If earth bonding of the work piece is required, bond it directly with a separate cable with a current carrying capacity capable of carrying the maximum capacity of the machine current. Cables (both primary supply and welding) should be regularly checked for damage and overheating. Never use worn, damaged, under sized or poorly jointed cables.

Insulate yourself from work and earth using dry insulating mats or covers big enough to prevent any physical contact.

Never touch the electrode if you are in contact with the work piece return.

Do not wrap cables over your body.

Ensure that you take additional safety precautions when you are welding in electrically hazardous conditions such as damp environments, wearing wet clothing and metal structures.

Try to avoid welding in cramped or restricted positions.

Ensure that the equipment is well maintained. Repair or replace damaged or defective parts immediately. Carry out any regular maintenance in accordance with the manufacturers instructions.

The EMC classification of this product is class A in accordance with electromagnetic compatibility standards CISPR 11 and IEC 60974-10 and therefore the product is designed to be used in industrial environment only.

WARNING: This class A equipment is not intended for use in residential locations where the electrical power is provided by a public low-voltage supply system. In those locations it may be difficult to ensure the electromagnetic compatibility due to conducted and radiated disturbances.

Materials and their disposal

Welding equipment is manufactured with BSI published standards meeting CE requirements materials which do not contain any toxic or poisonous materials dangerous to the operator.

Do not dispose of the equipment with normal waste. The European Directive 2012/19/EU on Waste Electrical and Electronic Equipment states the electrical equipment that has reached its end of life must be collected separately and returned to an environmentally compatible recycling facility for disposal.

For more detailed information please refer to the HSE website www.hse.gov.uk

What is the MMA Process?

Terms used

MMA - Manual metal arc SMAW -Shielded metal arc welding Stick welding

The Process

The manual metal arc process was first developed in Russia in 1888 and comprised a bare metal welding rod. In the early 1900's the coated electrode was introduced when the Kjellberg process was invented in Sweden. In the UK the Quasi arc method was introduced. The use of the coated electrode was slow due to the high production costs but the demand for higher integrity welds led to the process becoming increasingly used.

The material is joined when an arc is created between the electrode and work piece melting the work piece and the electrode to form a weld pool. At the same time the electrode has an outer coating sometimes called electrode flux which also melts and creates a shield over the weld pool to prevent contamination of the molten pool and assist in establishing the arc.

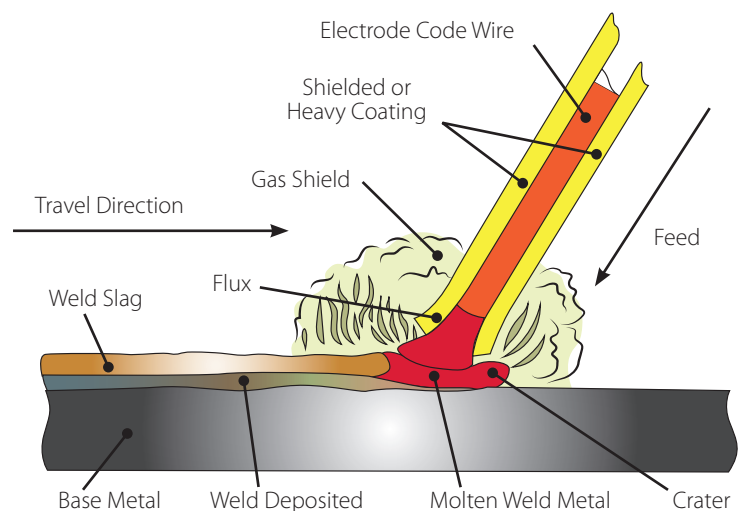

This cools and forms a hard slag over the weld which then needs to be chipped away from the weld bead upon completion or before another weld bead is added. The process allows only short lengths of weld to be produced due to the electrode length before a new electrode needs to be inserted in the holder. The quality of the weld deposit is highly dependent on the skill of the welder.

The power source provides a constant current (CC) output and can be either AC (alternating current) or DC (direct current).

The design of the MMA welder is such that the operator extending arc length will reduce the welding current and shortening the arc length (reducing the arc voltage) will do the opposite i.e. increase the current. As a guide the voltage controls the height and width of the weld bead whilst the current controls penetration, therefore the welder manipulates the electrode to achieve a satisfactory weld.

The power used in the welding circuit is determined by the arc voltage and current.

The voltage (V) is determined by the electrode diameter and the distance between the electrode and work piece. The current within the circuit is dependent on the electrode diameter, the thickness of the materials to be welded and the position of the weld. Most electrode information will show details of current types to be used and optimum current range.

MMA welding power sources which can TIG weld are often referred to as drooper's or drooping characteristic power sources. They are typically basic selector type, magnetic amplifier control or engine driven units with a robust design as they are often required to work in extreme conditions.

The characteristic of the output shape gave rise to the term "drooper".

The shape of the characteristic allowed the operator to control heat input and weld bead shape by electrode manipulation.

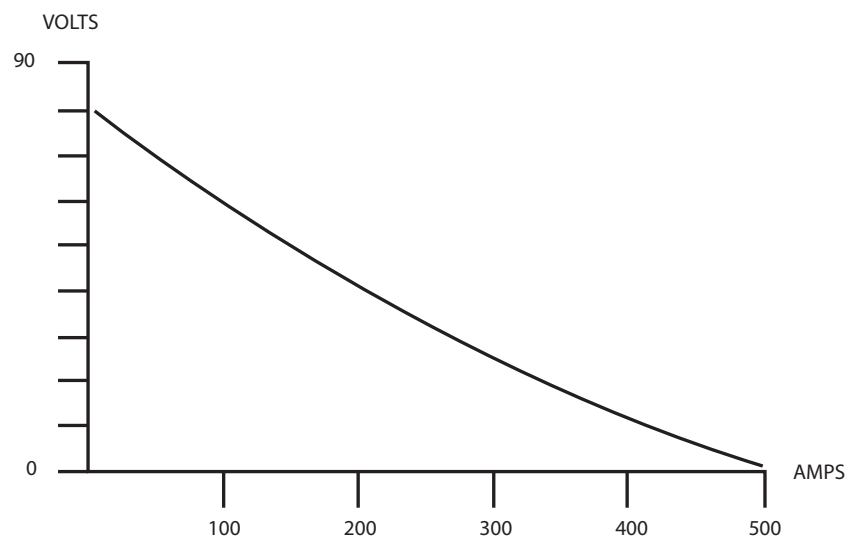

However, the TIG welder that can MMA weld had a much steeper characteristic curve which gave more problems to the welder as now the arc current remained constant despite large variations in arc voltage reducing the control by manipulation.

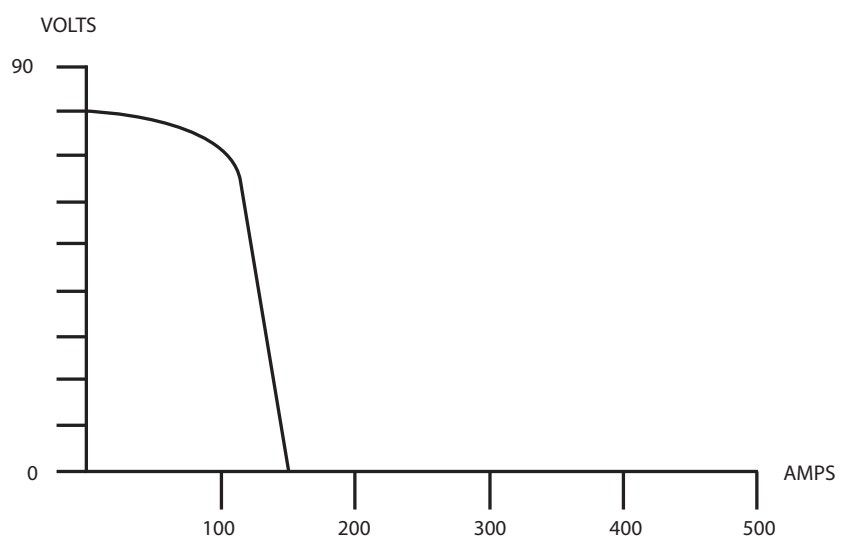

Modern inverter power supplies however can overcome these problems and provide excellent characteristic and performance as the curve can be controlled electronically for each process.

The small relatively cheap AC sets are generally used in the DIY or small maintenance functions and some larger AC sets often oil cooled may be used in heavier industry but the DC output set are now the most common in use.

Electrode manufacture means that not all DC electrodes can operate on AC power sources but AC electrodes can operate on both AC and DC. Direct current (DC) is the most commonly used mode. Control of AC units tends to be moving iron core or switched transformers.

DC output power sources can be used on many material types and can be obtained in wide current ranges. Controls of these units vary from moving iron core control to the latest inverter designs. Inverter design has brought many advantages as they are:

- Very lightweight and portable compared to their predecessors
- Very energy efficient power supply and offer energy cost savings
- Able to provide higher outputs for lower inputs
- High levels of control and performance

In general it is preferable to weld in the flat or horizontal position. When welding in position is required such as vertical or overhead it is useful to reduce the welding current compared to the horizontal position. For best results in all positions maintaining a short arc, uniform movement and travel speed in addition to consistent feeding of the electrode are required.

What makes up the MMA System?

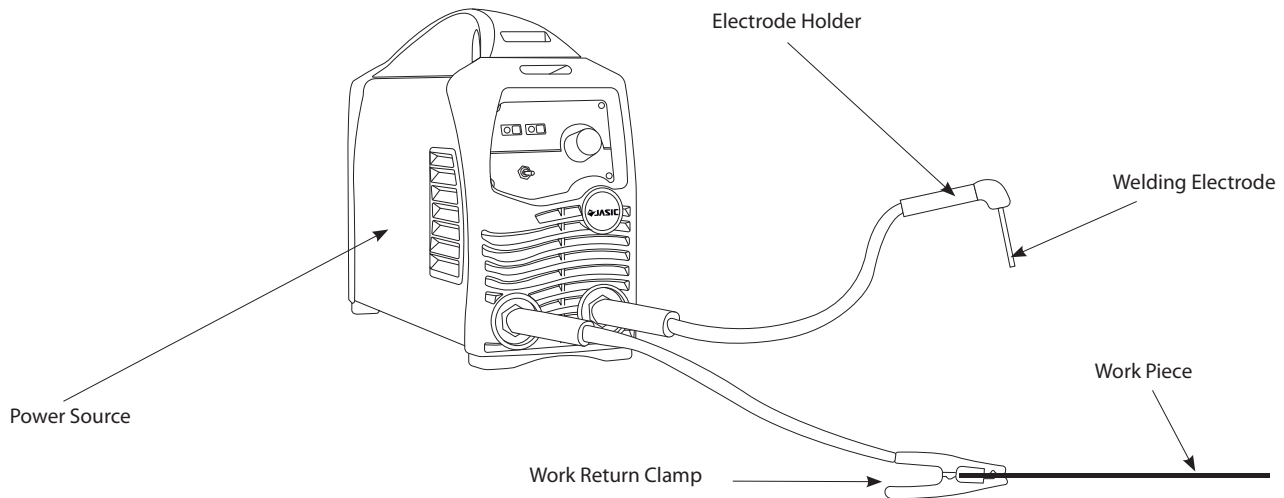

The set up of the welding circuit is shown (above) with most power sources having only a current control feature as current is the most practical indicator of power in the circuit. Voltage in the MMA process is generally governed by the arc length during welding and electrode diameter.

The current required to perform MMA welding is dependent on the electrode diameter being used. The smaller the electrode the less current is required to melt it. Also, the thinner the material to be welded the less current is required.

The Power Source

The power source selected should have sufficient power to melt the electrode and weld material with enough capacity to maintain the arc voltage. The MMA process typically requires high current (50-350A) at relatively low voltage (10-50V). The MMA electrodes are designed to operate on different types of output power and voltage and you should always read the manufacturers data.



All electrodes can be used on direct current (DC) but not all on alternating current (AC). Some AC electrodes also have certain voltage requirements. When used in the DC mode the electrode lead should be connected to the polarity recommended by the electrode manufacturer, in most cases this will be electrode positive polarity but there are electrodes that use electrode negative polarity. The power source operates with a “no load” or “open circuit voltage” present when no welding arc is struck. This no load voltage rating is defined in the standard EN 60974-12012 (EN 60974) in accordance with the welding environment or risk of electrical shock. The power source may have a voltage reduction device (VRD) fitted either internally or externally.

This reduces the no load voltage to a lower level (normally between 12 & 30 Volts) until an arc is struck at which point the main welding current and voltage are delivered.

Typical power sources are:

- AC output transformer
- AC/DC transformer rectifier
- AC/DC inverter
- Engine driven DC or AC output



The Electrode Holder and Cables

The electrode holder clamps the end of the electrode with conductive clamps built into its head. These clamps operate either by a twist action or spring-loaded clamp action (crocodile type).

The clamping mechanism allows for the quick release of the remaining unused electrode end (stub end). To ensure the maximum welding efficiency the electrode has to be firmly clamped into the holder, otherwise poor electrical contact may cause arc instability through voltage fluctuations and overheating of the holder. The welding cable is connected to the holder either mechanically, crimped or soldered.

Electrode holders should conform to IEC 60974-11.

It is essential to ensure all connections are good between electrode, holder and cable.

Where a poor connection exists resistance heating and, in severe cases, minor arcing with the torch body will cause the holder to overheat. There are two cables from the output of the power source, the welding lead goes to the electrode holder and the work return lead is clamped to the work piece.

The latter is often wrongly referred to as the earth lead.

A separate earth lead may be required to provide protection from faults in the power source. The earth cable should therefore be capable of carrying the maximum output current of the power source. Cables are covered in a smooth and hard-wearing protective flexible sheath. This can be either rubberised or PVC and must conform to the relevant standard. The sheath will be an oil and water resistant coating providing electrical insulation at voltages to earth not exceeding 100V DC and AC (rms value).



Welding cable diameter is generally selected on the basis of welding current level. The higher the current and duty cycle, the larger the diameter of the cable to ensure that it does not overheat (see relevant standard). If welding is carried out some distance from the power source, it may be necessary to increase cable diameter to reduce voltage drop.

Nominal cross sectional area of the conductors	Maximum dia of conductor wire (strand)	Thickness of covering	Mean overall diameter	Maximum conductor resistance at 20°C	Capacity of conductor at 60% duty cycle
mm ²	mm	mm	mm	Ohms/km	Amperes
16	0.31	1.8	8.2	1.21	175
25	0.31	2.0	10.2	0.780	230
35	0.31	2.2	12.0	0.554	290
50	0.31	2.4	13.5	0.386	365
70	0.31	2.6	15.6	0.272	460
90	0.31	2.8	18.2	0.206	560
120	0.31	3.0	20.4	0.161	650

The Electrode

The electrode consists of a core material of the material type i.e. steel or stainless steel etc. which provides the weld filler metal. This is covered by an outer coating called a flux which helps in creating the arc and shields the arc from contamination with what is called slag.

Types of Flux/Electrodes

The stability of the arc, depth of penetration, metal deposition rate and positional features are significantly influenced by the chemical composition of the flux coating on the electrode. Electrodes can be divided into three main types:

- Basic
- Cellulosic
- Rutile



Basic Electrodes

Basic electrodes contain a high proportion of calcium carbonate (limestone) and calcium fluoride (fluorspar) in the coating. This makes their slag coating more fluid than rutile coatings - this is also fast-freezing which assists welding in the vertical and overhead position. These electrodes are used for welding medium and heavy section fabrications where higher weld quality, good mechanical properties and resistance to cracking (due to high restraint) are required.

Features:

- Low hydrogen weld metal
- Requires high welding currents/speeds
- Poor bead profile (convex and coarse surface profile)
- Slag removal difficult

When these electrodes are exposed to air moisture pick-up is rapid. Because of the need for hydrogen control these electrodes should be thoroughly dried in a controlled temperature drying oven. Typical drying time is one hour at a temperature of approximately 150°C to 300°C but you should always consult the manufacturer data before use.

After controlled drying, basic and basic/rutile electrodes must be held at a temperature between 100°C and 150°C to help protect them from re-absorbing moisture into the coating. These conditions can be obtained by transferring the electrodes from the main drying oven to a holding oven or a heated quiver at the workplace.

Metal Powder Electrodes

Metal powder electrodes contain an addition of metal powder to the flux coating to increase the maximum permissible welding current level. Thus, for a given electrode size, the metal deposition rate and efficiency (percentage of the metal deposited) are increased compared with an electrode containing no iron powder in the coating.

The slag is normally easily removed. Iron powder electrodes are mainly used in the flat and H/V positions to take advantage of the higher deposition rates. Efficiencies as high as 130-140% can be achieved for rutile and basic electrodes without marked deterioration of the arcing characteristics but the arc tends to be less forceful which reduces bead penetration.

NOTE: The quality of weld relies upon consistent performance of the electrode. The flux coating should not be chipped, cracked or more importantly, allowed to become damp. Electrodes are made with different types of coating and require different handling.

Cellulosic Coatings

Cellulosic electrodes contain a high proportion of cellulose in the coating and are characterised by a deeply penetrating arc and a rapid burn-off rate giving high welding speeds. Weld deposit can be coarse and with fluid slag, de slagging can be difficult. These electrodes are easy to use in any position and are noted for their use in the 'stovepipe' welding technique.

Features:

- Deep penetration in all positions
- Suitability for vertical down welding
- Reasonably good mechanical properties
- High level of hydrogen generated - risk of cracking in the heat affected zone (HAZ)

These electrode coatings are designed to operate with a definite amount of moisture in the coating. The coating is less sensitive to moisture pick-up and does not generally require a drying operation. However, drying may be necessary in cases where ambient relative humidity in which the electrodes have been stored in, has been very high.

Rutile Electrodes

Rutile electrodes contain a high proportion of titanium oxide (rutile) in the coating. Titanium oxide promotes easy arc ignition, smooth arc operation and low spatter. These electrodes are general purpose electrodes with good welding properties. They can be used with AC and DC power sources and in all positions. The electrodes are especially suitable for welding fillet joints in the horizontal/vertical (H/V) position.

Features:

- Moderate weld metal mechanical properties
- Good bead profile produced through the viscous slag
- Positional welding possible with a fluid slag (containing fluoride)
- Easily removable slag

The rutile coatings can tolerate a limited amount of moisture and coatings may deteriorate if they are over dried. Always consult the manufacturer data before use.

Hard / Wear Facing Electrodes

Hard facing or wear electrodes are used primarily to put a hard surface over a softer base material. There is an extensive range of these types of products and a common use area is the repair of wearing surfaces such as teeth on earth moving and mining equipment.

DC Copper Coated Electrodes

This is the most common type because of its comparatively long electrode life. These electrodes are constructed by mixing and baking carbon, graphite and a binding agent and coating them with copper. They provide stable arc characteristics and uniform grooves.

DC Plain Electrodes

These are constructed in the same way as the DC copper coated electrode but without the copper coating. They are more rapidly consumed compared to copper coated in use.

AC Coated Electrodes

These electrodes are constructed by mixing and baking carbon, graphite and a special binding agent with added rare earth materials to help with arc stabilization.

They are copper coated.

The process uses compressed air at between 80-100 psi at the electrode holder.

Increasing air pressure will not remove metal more efficiently.

Electrode Storage

Electrodes should always be kept in a dry and well-ventilated store. It is good practice to stack packets of electrodes on wooden pallets or racks well clear of the floor. Also, all unused electrodes which are to be returned should be stored so they are not exposed to damp conditions to regain moisture. Good storage conditions are 10°C above external air temperature. As the storage conditions are to prevent moisture from condensing on the electrodes, the electrode stores should be dry.

Under these conditions and in original packaging, electrode storage time is practically unlimited.

Modern electrodes are now available in hermetically sealed packs which remove the need for drying.

However, if necessary, any unused electrodes must be redried according to manufacturer's instructions.

Drying of Electrodes

Drying is usually carried out in accordance with the manufacturer's recommendations and requirements will be determined by the type of electrode.

Many electrodes are now available in hermetically sealed containers. These vacuum packs obviate the need for drying the electrodes immediately prior to use. If however the container has been opened or damaged, it is essential that the electrodes are re-dried according to the manufacturer's instructions.

Electrode Selection

The electrode diameter selection is based on the work piece thickness, welding position, joint form, welding layer etc.

Welding current level is determined by the size of electrode - the normal operating range and current are recommended by manufacturers. Typical operating ranges for a selection of electrode sizes are illustrated in the table.

Typical Electrode Current Guide

DC Electrode Diameter mm	Min Current	Max Current	Average Current
1.6	25	45	40
2.0	34	65	50
2.5	50	90	90
3.2	60	130	115
4.0	100	180	140
5.0	150	250	200
6.0	200	310	280

- Electrodes should be dry and used according to the instructions. This will reduce the hydrogen in the molten pool and welding seam, avoiding the blowholes and cold cracking.
- In the welding process, the arc must not be too long; otherwise, it will cause unstable arc burning, large amounts of spatter, light penetration, undercut, blowholes etc. If the arc is too short, it will cause electrode sticking to the work piece.
- In MMA welding the arc length is usually equal to 0.5~1.0 times the diameter of the electrode. The basic electrode's arc length is not more than the electrode diameter and short arc welding is preferred. When using acid electrodes the arc length is equal to the electrode diameter.

Gouging Electrodes

Arc gouging is the process of eliminating excess metal through the use of a specialized flux covered electrode instead of a torch or grinding with the distinction of being able to work under water. Specially produced acidic, rutile, cellulosic and iron powder electrodes 4 to 6mm in diameter produce a cutting or gouging arc.

A cutting current of approx 60A per mm is required. Electrode holders should be specially designed to withstand such high currents. The arc produced by these electrodes releases a high pressure gas stream from the fast burning of the material in the electrode coating, this gas stream removes the molten metal. The cut edges are rough and need cleaning and preparation afterwards.

Arc Air Gouging

There are three types of electrode used for air carbon arc gouging.

Electrode Diameter	DC Electrode Positive		AC Electrode		DC Electrode Negative	
	Minimum Amps	Maximum Amps	Minimum Amps	Maximum Amps	Minimum Amps	Maximum Amps
3.2	60	90				
4.0	90	150				
4.8	200	250	200	250	150	180
6.4	300	400	300	400	200	250
7.9	350	450				
9.5	450	600	350	450	300	400
12.7	800	1000				

Welding Fume

Welding fume consists of various airborne substances in the form of fine particles and gases. These elements may increase hazards to health if they are inhaled or swallowed.

The degree of hazard to the welder will depend on:

- The time the welder is exposed to the fume
- The composition of the fume
- The concentration of the fume in the air that he/she is breathing



When the consumable electrodes are at a normal ambient temperature the no fumes or gases are created. However, the MMA process when welding can produce fume due to both the molten weld metal and electrode coatings.

For more detail on welding fume please consult with the electrode manufacturer's data and recommendations or visit the Health & Safety Executive (HSE) website for more information (WL9 – COSHH essentials for welding, hot work and allied processes).

Occupational Exposure Limits

The recommended limit on the concentration of welding fume in the air breathed by any person is defined by the Health & Safety Executive in a list of Occupational Exposure Limits (guidance note EH40).

This guidance note is revised annually and reference should always be the most recent edition. A long term exposure limit (8hr TWA value) of $5\text{mg}/\text{m}^3$ for particulate welding fume is included in the current list.

It is the responsibility of the welder and employer under the Health & Safety at Work Act and the Control of Substances Hazardous to Health (COSHH) regulations that limits are not exceeded. The fume analysis provided by the electrode manufacturer cannot be used to assess the concentration of total welding fume to which a welder is exposed.

An assessment of the possible exposure of the welder to fume must be carried out by a competent person.

Controls used in MMA

Typical Basic Control Panel



Current Control (A)

The current control regulates the amount of current output from the machine and hence the deposition rate dependent on the electrode diameter.

Often current can be controlled via remote controls on more modern electronic power sources.

Hot Start

At the start of welding the hot start provides an increased amount of current to enable the electrode to strike the arc without sticking to the work piece. Some machines have an automatic hot start current with a set time and level others have variable hot start control for an operator to select.

Arc Force

During welding the arc voltage is normally in the region of 20V. Often the situation may demand a shorter arc which results in a lower voltage and the electrode is prone to “sticking to the work piece” as the arc has actually extinguished. The arc force control will overcome this problem by increasing the current when the arc voltage falls to ensure the metal transfer of the electrode and prevent the electrode sticking. Some machines have an automatic arc force current others have variable arc force control for an operator to select the required level.

MMA Process Features & Benefits

The versatility of the process and the skill level required to learn, basic simplicity of the equipment make the MMA process one of the most common used throughout the world.

The MMA process can be used to weld a wide variety of materials and is normally used in the horizontal position but can be used in vertical or overhead with the correct selection of electrode and current. In addition, it can be used to weld at long distances from the power source subject to the correct cable sizing. The self shielding effect of the electrode coating makes the process suitable for welding in external environments. It is the dominant process used in maintenance and repair industries and is used extensively in structural and fabrication work.

The process is well able to cope with less than ideal material conditions such as dirty or rusty material. Disadvantages of the process are the short welds, slag removal and stop starts which lead to poor weld efficiency which is in the region of 25%. The weld quality is also highly dependent on the skill of the operator and many welding problems can exist.

MMA Process Tips & Guides

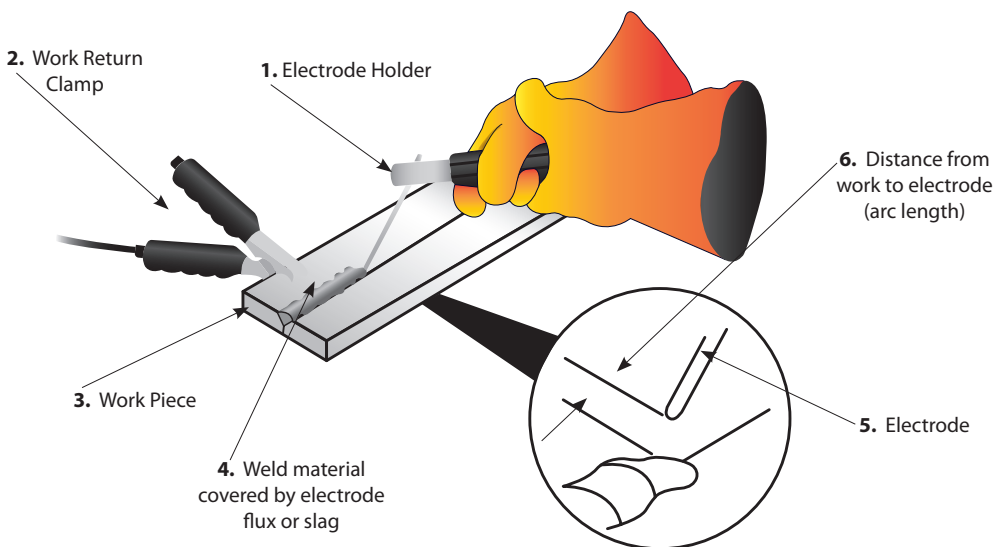

Typical Welder Set Up

1. Electrode Holder
2. Work Return Clamp
3. Work Piece
4. Weld material covered by electrode flux or slag
5. Electrode
6. Distance from work to electrode (arc Length)

Welding current will flow in the circuit as soon as the electrode contacts the work piece. The welder should always ensure a good connection of the work clamp. The nearer the clamp is placed to the weld zone the better.

When the arc is struck the distance between the end of the electrode and the work will determine the arc voltage and also affect the weld characteristic. As a guide the arc length for electrodes up to 3.2mm diameter should be around 1.6mm and over 3.2mm around 3mm.

Upon completion of the weld the welding flux or slag will need to be removed usually with a chipping hammer and wire brush.

Joint Form in MMA

In MMA welding, the common basic joint forms: butt joint, corner joint, lap joint & T joint.

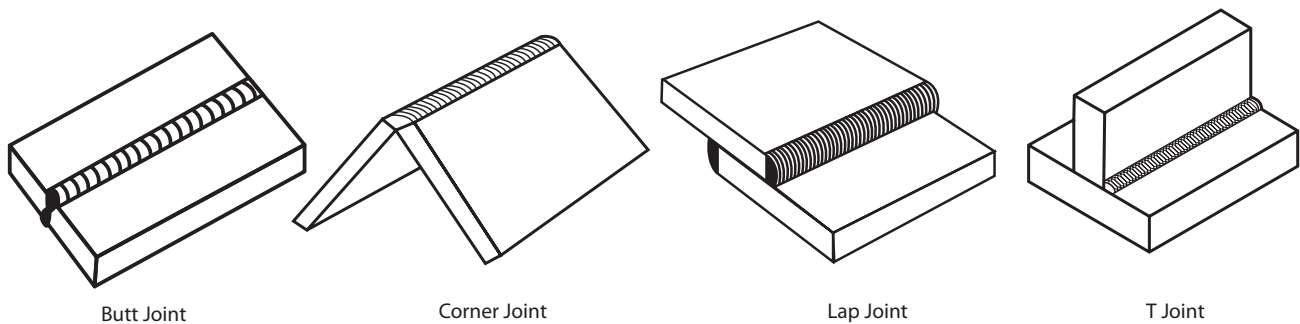

MMA Arc Striking

Tap Technique - Lift the electrode upright and bring it down to strike the work piece. After forming short circuit, quickly lift up about 2~4 mm, and arc will be ignited. This method is difficult to master.

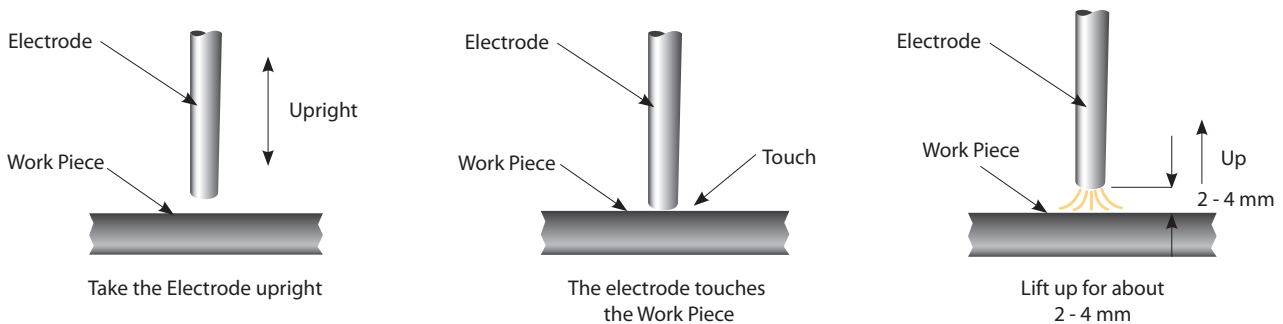

Scratch Technique - Drag the electrode and scratch the work piece as if striking a match. Scratching the electrode may cause the arc to burn along the scratch path, so care should be taken to scratch in the weld zone. When the arc is struck adopt the correct welding position.

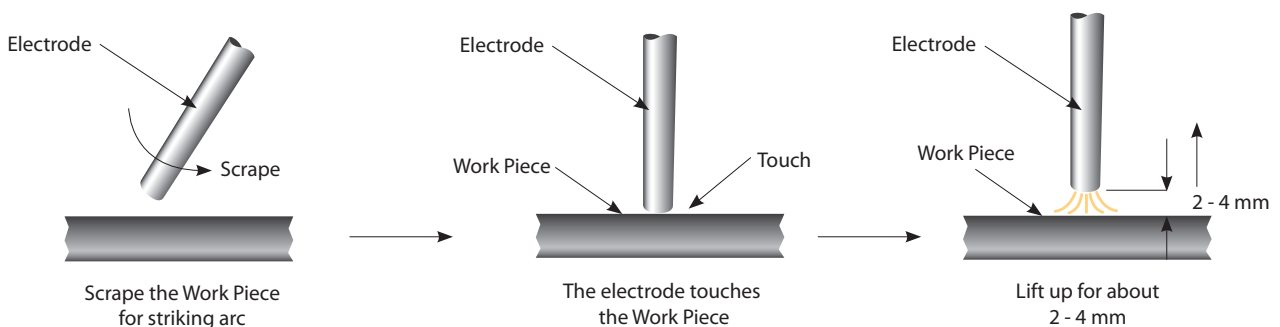

Electrode Positioning

Horizontal or Flat Position

The electrode should be positioned at right angles to the plate and inclined in the direction of travel at around 10° - 30° .

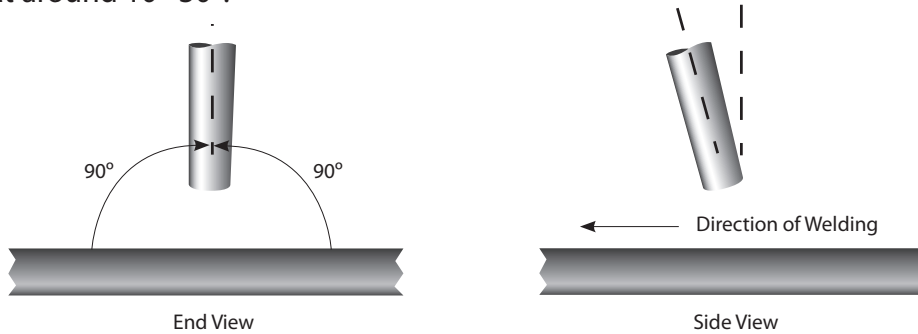

Fillet Welding

The electrode should be positioned to split the angle i.e. 45° . Again the electrode should be inclined in the direction of travel at around 10° - 30° .

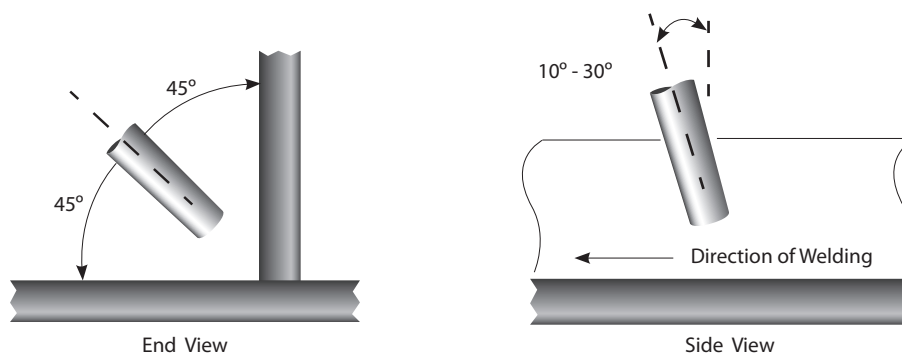

Manipulation of Electrode

In MMA welding there are three motions used at the end of electrode:

- 1 The electrode feeding to the molten pool along axes
- 2 The electrode swing right and left
- 3 The electrode moving in the weld direction

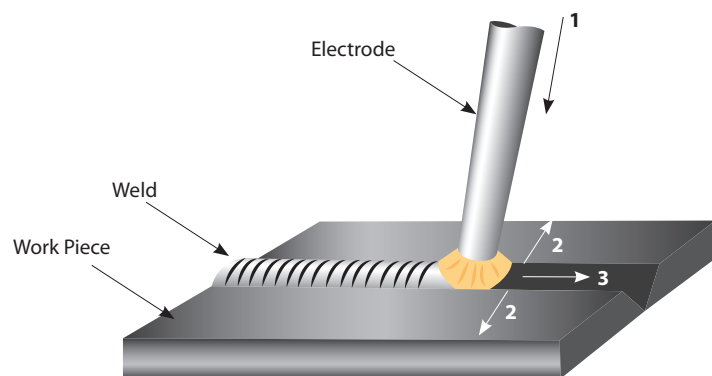

1. Electrode moving
2. The electrode swing right and left
3. The electrode move along weld

The operator can choose the manipulation of electrode based on welding joint, welding position, electrode spec, welding current and operation skill etc.

Weld Characteristics

A good weld bead should exhibit the following characteristics:

- 1 Uniform weld bead
- 2 Good penetration into the base material
- 3 No overlap
- 4 Fine spatter level

A poor weld bead should exhibit the following characteristics:

- 1 Uneven and erratic bead
- 2 Poor penetration into the base material
- 3 Bad overlap
- 4 Excessive spatter levels
- 5 Weld crater

Arc Welding Defects & Prevention Methods

Defect	Possible Cause	Action
Excessive spatter – beads of metal scattered around the weld area	Amperage too high for the selected electrode Voltage too high or arc length too long	Reduce amperage or utilise larger diameter electrode Reduce arc length or voltage
Uneven and erratic weld bead and direction	Weld bead is inconsistent and misses joint due to operator	Operator training required
Lack of penetration – The weld bead fails to create complete fusion between material to be welded, often surface appears okay but weld depth is shallow	Poor joint preparation	Joint design must allow for full access to the root of the weld
	Insufficient heat input	Material too thick Increase the amperage or increase the electrode size and amperage
Porosity – Small holes or cavities on the surface or within the weld material	Poor weld technique	Reduce travel speed Ensure the arc is on the leading edge of the weld puddle
	Work piece dirty Electrode is damp Arc length is excessive	Remove all contaminant from the material i.e. oil, grease, rust, moisture prior to welding Replace or dry the electrode Reduce the arc length
Excessive penetration – The weld metal is below the surface level of the material and hangs below	Heat input too high	Reduce the amperage or use a smaller electrode and lower amperage
	Poor weld technique	Use correct welding travel speed
Burning through – Holes within the material where no weld exists	Heat input too high	Use lower amperage or smaller electrode Use correct welding travel speed
	Insufficient heat level	Increase the amperage or increase the electrode size and amperage
Poor fusion – Failing of weld material to fuse either with the material to be welded or previous weld beads	Poor welding technique	Joint design must allow for full access to the root of the weld Alter welding technique to ensure penetration such as weaving, arc positioning or stringer bead technique
	Work piece dirty	Remove all contaminant from the material i.e. oil, grease, rust, moisture prior to welding

NOTES

A series of horizontal dashed lines for writing notes.

MMA WELDING



JASIC

The power in inverter technology

5 Year
Warranty
ON ALL MODELS



@jasicuk



@wilkinsonstaruk



WILKINSON STAR

0161 793 8127

wilkinsonstar.com