

RotabroachTM

ELEMENT 50 LOWPROFILE

Magnetic drilling machine

Model Number

ELEMENT 50 LOW PROFILE 1, ELEMENT 50 LOW PROFILE 3

This machine (Serial Number) is CE approved.



Rotabroach[®]

**OSL Cutting Technologies Ltd
Burgess Road
Sheffield, South Yorkshire
United Kingdom
S9 3WD**

**Tel: +44 (0) 114 2212 510
Email: info@rotabroach.co.uk**

**Fax: +44 (0) 114 2212 563
Website: www.rotabroach.co.uk**

**Thank you for purchasing our Low-Profile magnetic drill.
We would really like your feedback on this machine.**

Other Products by Rotabroach:



Thank you for your purchase

CONTENTS OF THE MANUAL

	Page
1) Intended use	4
2) General safety rules	4
3) Information plate symbols	5
4) Specification	6
5) Operational safety procedures	7
6) Operating instructions	7
7) Control panel operation	8
8) Extension cable selection	9
9) Mounting of cutters	9
10) Remedies for hole making problems	10
11) Wiring diagram	11
12) Exploded view	12
13) Motor Breakdown	15
14) Control panel and parts list	16
15) Pipe adapter kit RD2311	17
16) Maintenance	18
17) Trouble shooting	19
18) Cutter selection, speeds and feeds	20
19) Warranty	21

Part	Description	Quantity
RDF4030	4mm Hexagonal Wrench	2
RDF4031	Coolant Bottle	1
RDF4032	Ratchet Handle	1
RD4329B	Black Safety Strap	1
RDF4033	Safety Goggles	1
RDF3005	Carbon Brush Set	1

1) INTENDED USE

The intended use of this magnetic drill is to drill holes in ferrous metals. The magnet is used to hold the drill in place whilst the drill is functioning. It is designed for use in fabrication, construction, railways, petrochemical and any other applications when drilling ferrous metal.

Any deviation from its intended use will not be covered by warranty.

2) GENERAL SAFETY RULES

WARNING! Read all safety warnings, instructions, illustrations and specifications provided with this power tool. Failure to follow all instructions listed below may result in electric shock, fire and/or serious injury.

Save all warnings and instructions for future reference.

The term "power tool" in the warnings refers to your mains-operated (corded) power tool or battery-operated (cordless) power tool.

Work area safety

Keep work area clean and well lit. Cluttered or dark areas invite accidents.

Do not operate power tools in explosive atmospheres, such as in the presence of flammable liquids, gases or dust. Power tools create sparks which may ignite the dust or fumes.

Keep children and bystanders away while operating a power tool. Distractions can cause you to lose control.

Electrical safety

- Power tool plugs must match the outlet. Never modify the plug in any way. Do not use any adapter plugs with earthed (grounded) power tools.** Unmodified plugs and matching outlets will reduce risk of electric shock.
- Avoid body contact with earthed or grounded surfaces, such as pipes, radiators, ranges and refrigerators.** There is an increased risk of electric shock if your body is earthed or grounded.
- Do not expose power tools to rain or wet conditions.** Water entering a power tool will increase the risk of electric shock.
- Do not abuse the cord. Never use the cord for carrying, pulling or unplugging the power tool. Keep cord away from heat, oil, sharp edges or moving parts.** Damaged or entangled cords increase the risk of electric shock.
- When operating a power tool outdoors, use an extension cord suitable for outdoor use.** Use of a cord suitable for outdoor use reduces the risk of electric shock.
- If operating a power tool in a damp location is unavoidable, use a residual current device (RCD) protected supply.** Use of an RCD reduces the risk of electric shock.

NOTE The term "residual current device (RCD)" can be replaced by the term "ground fault circuit interrupter (GFCI)" or "earth leakage circuit breaker (ELCB)".

Personal safety

- Stay alert, watch what you are doing and use common sense when operating a power tool. Do not use a power tool while you are tired or under the influence of drugs, alcohol or medication.** A moment of inattention while operating power tools may result in serious personal injury.
- Use personal protective equipment. Always wear eye protection.** Protective equipment such as a dust mask, non-skid safety shoes, hard hat or hearing protection used for appropriate conditions will reduce personal injuries.
- Prevent unintentional starting. Ensure the switch is in the off-position before connecting to power source and/or battery pack, picking up or carrying the tool.** Carrying power tools with your finger on the switch or energising power tools that have the switch on invites accidents.
- Remove any adjusting key or wrench before turning the power tool on.** A wrench or a key left attached to a rotating part of the power tool may result in personal injury.
- Do not overreach. Keep proper footing and balance at all times.** This enables better control of the power tool in unexpected situations.
- Dress properly. Do not wear loose clothing or jewellery. Keep your hair and clothing away from moving parts.** Loose clothes, jewellery or long hair can be caught in moving parts.
- If devices are provided for the connection of dust extraction and collection facilities, ensure these are connected and properly used.** Use of dust collection can reduce dust-related hazards.
- Do not let familiarity gained from frequent use of tools allow you to become complacent and ignore tool safety principles.** A careless action can cause severe injury within a fraction of a second.

Power tool use and care

- a) **Do not force the power tool. Use the correct power tool for your application.** *The correct power tool will do the job better and safer at the rate for which it was designed.*
- b) **Do not use the power tool if the switch does not turn it on and off.** *Any power tool that cannot be controlled with the switch is dangerous and must be repaired.*
- c) **Disconnect the plug from the power source and/or remove the battery pack, if detachable, from the power tool before making any adjustments, changing accessories, or storing power tools.** *Such preventive safety measures reduce the risk of starting the power tool accidentally.*
- d) **Store idle power tools out of the reach of children and do not allow persons unfamiliar with the power tool or these instructions to operate the power tool.** *Power tools are dangerous in the hands of untrained users.*
- e) **Maintain power tools and accessories. Check for misalignment or binding of moving parts, breakage of parts and any other condition that may affect the power tool's operation. If damaged, have the power tool repaired before use.** *Many accidents are caused by poorly maintained power tools.*
- f) **Keep cutting tools sharp and clean.** *Properly maintained cutting tools with sharp cutting edges are less likely to bind and are easier to control.*
- g) **Use the power tool, accessories and tool bits etc. in accordance with these instructions, taking into account the working conditions and the work to be performed.** *Use of the power tool for operations different from those intended could result in a hazardous situation.*
- h) **Keep handles and grasping surfaces dry, clean and free from oil and grease.** *Slippery handles and grasping surfaces do not allow for safe handling and control of the tool in unexpected situations.*

Service

Have your power tool serviced by a qualified repair person using only identical replacement parts. *This will ensure that the safety of the power tool is maintained*

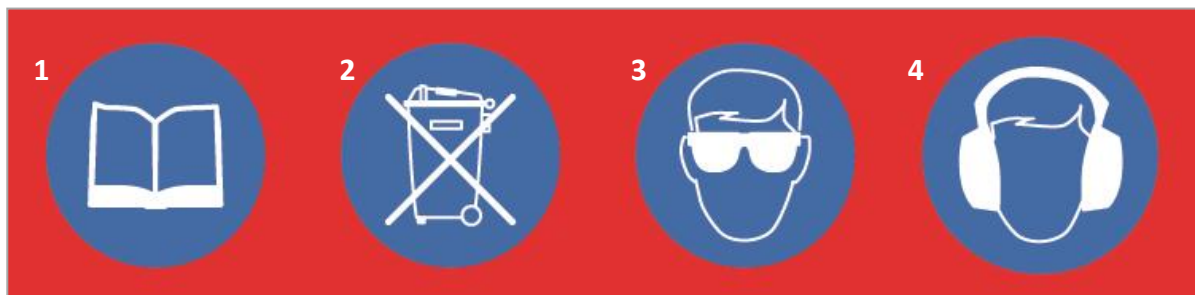
3) INFORMATION PLATE SYMBOLS

1. Refer to the user manual for operational and safety issues regarding this machine.
2. Dispose of the machine and electrical components correctly.
3. Eye protection must be worn when operating the machine.
4. Ear defenders must be worn when operating the machine.

4) SPECIFICATION

Maximum hole cutting capacity in .2/.3C steel = 50mm dia. x 50mm deep

Arbor bore = 19.05mm (3/4") dia.

Motor Unit				
Voltages	110V 50-60Hz		230V 50-60Hz	
Normal full load	10 A	1200 W	6 A	1200 W
Electro Magnet	0.53 A	56W	0.28 A	61W
Size	192mm long 82 mm wide			
Holding Force at 20°C with 25mm minimum plate thickness The use on any material less than 25mm thick will progressively reduce the magnetic performance. If possible, substitute material should be positioned under the magnet and work piece to equate to a suitable material thickness. If this is not possible, an alternative secure method of restraining the machine MUST be used.	10000N			
Overall Dimensions				
Height - minimum	179mm			
Width (including Capstan fitting)	100mm			
Length Overall (including Guard)	334mm			
Nett Weight	11 kgs			
	ELEMENT 50 LOW PROFILE 1		ELEMENT 50 LOW PROFILE 3	
Vibration total values (triax vector sum) in accordance with EN62841-1:	Vibration emission value a W= 5,782 m/s ² Uncertainty(K):1.5m/s ²		Vibration emission value a W= 5,735 m/s ² Uncertainty(K):1.5m/s ²	
Level of sound pressure in accordance with EN62841-1:	LpA: 85 dB(A) LwA: 98 dB(A) uncertainty(K): 3dB(A)		LpA: 84 dB(A) LwA: 97 dB(A) uncertainty(K): 3dB(A)	

Vibration and Noise

The declared vibration total value(s) and the declared noise emission value(s) have been measured in accordance with a standard test method and maybe used for comparing one tool with another;

The declared vibration total value(s) and declared noise emission values(s) may also be used in a preliminary assessment of exposure.

The vibration and noise emissions during actual use of the power tool can differ from the declared total value depending on the ways in which the tool is used and especially what kind of workpiece is being processed

The need to identify safety measures to protect the operator that are based on an estimation of exposure in the actual conditions of use (taking account of all parts of the operating cycle such as the times when the tool is switched off and when it is running idle in addition to the trigger time).

Ear and eye defenders must be worn when operating this machine. Wear gloves to protect hands when operating the machine.

These tools are UK designed and manufactured with globally sourced components and conform to the requirements of EEC Document HD.400.1 and BS.2769/84

Suitable only for a single phase 50-60Hz A.C. power supply

DO NOT USE ON D.C. SUPPLY

Do not use your magnetic drill on the same structure when arc welding is in progress.

D.C. current will earth back through the magnet and cause irreparable damage.

WARNING: THIS APPLIANCE MUST BE EARTHED!

NB: ANY MODIFICATIONS TO THIS MACHINE WILL INVALIDATE THE GUARANTEE

5) OPERATIONAL SAFETY PROCEDURES

READ BEFORE USING THE MACHINE

- When using electrical tools, basic safety precautions should always be followed to reduce the risk of electric shock, fire, and personal injury.
- Ensure the magnet is OFF before plugging in the machine.
- Do NOT use in wet or damp conditions. Failure to do so may result in personal injury.
- Do NOT use in the presence of flammable liquids, gases or in high risk environments. Failure to do so may result in personal injury.
- BEFORE activating the machine, inspect all electrical supply cables (including extension leads), and replace if damaged. DO NOT use if there are any signs of damage.
- Only use extension cables approved for site conditions.
- BEFORE activating the machine, ALWAYS check the correct function of all operational systems, switches, magnet etc.
- BEFORE operating, the machine MUST be securely restrained to a fixed independent feature (by using safety strap RD4329B, or other means) to reduce the potential free movement, should the magnet become detached from the work piece. Failure to do so may result in personal injury.
- ALWAYS wear approved eye protectors, ear defenders and recommended PPE at ALL times when operating the machine.
- Disconnect from power source when changing cutters or working on the machine.
- Cutters and swarf are sharp, ALWAYS ensure that hands are adequately protected when changing cutters or removing swarf. Use a tool or brush where necessary to remove any swarf or the cutter from the arbor.
- Before operating the machine, ALWAYS ensure cutter-retaining screws are secured tightly.
- Regularly clear the work area and machine of swarf and dirt, paying particular attention to the underside of the magnet base.
- ALWAYS remove tie, rings, watches and any loose adornments that might entangle with the rotating machinery before operating.
- ALWAYS ensure that long hair is securely enclosed by an approved restraint before operating the machine.
- Should the cutter become stuck in the work piece, stop the motor immediately to prevent personal injury. Disconnect from power source and turn arbor to and fro. DO NOT ATTEMPT TO FREE THE CUTTER BY SWITCHING THE MOTOR ON AND OFF. Wear safety gloves to remove the cutter from the arbor.
- If the machine is accidentally dropped, ALWAYS thoroughly examine the machine for signs of damage and check that it functions correctly BEFORE resuming drilling.
- Regularly inspect the machine and check for any damaged or loose parts.
- ALWAYS ensure when using the machine in an inverted position that only the minimum amount of coolant is used, and that care is taken to ensure that coolant does not enter the motor unit.
- Cutting tools may shatter, ALWAYS position the guard over the cutter before activating the machine. Failure to do so may result in personal injury.
- On completion of the cut, a slug will be ejected. DO NOT operate the machine as the ejected slug may cause injury.
- When not in use ALWAYS store the machine in a safe and secure location.
- ALWAYS ensure that approved ROTABROACH™ agents conduct repairs.

6) OPERATING INSTRUCTIONS

- Keep the inside of the cutter clear of swarf. It restricts the operating depth of the cutter.
- Ensure that the coolant bottle contains sufficient cutting oil to complete the required operating duration. Refill as required.
- Occasionally depress the pilot to ensure cutting fluid is being correctly metered.
- To start the machine, follow the control panel operation instructions.
- ALWAYS switch off the motor by depressing the MOTOR stop button. DO NOT switch off the motor by depressing the MAGNET switch.
- Apply light pressure when commencing the cut of a hole until the cutter is introduced into the work surface. Pressure can then be increased sufficiently to load the motor. Excessive pressure is undesirable, it does not increase the speed of penetration and will cause the safety overload protection device to stop the motor, (the motor can be restarted by operating the motor start button), and may cause excessive heat which may result in inconsistent slug ejection
- Always ensure that the slug has been ejected from the previous hole before commencing to cut the next.
- If the slug sticks in the cutter, move the machine to a flat surface, switch on the magnet and gently bring the cutter down to make contact with the surface. This will usually straighten a cocked slug and allow it to eject normally.
- Apply a small amount of light oil lubricant regularly to the slide and arbor support bearing.
- Cutter breakage is usually caused by insecure anchorage, a loosely fitting slide or a worn bearing in the arbor support. (Refer to routine maintenance instructions).
- Only use approved cutting fluid. Rotabroach cutting fluid has been specially formulated to maximise the cutters performance. It is available in 1 litre (RD208) and 5 litre (RD229).

7) CONTROL PANEL OPERATION

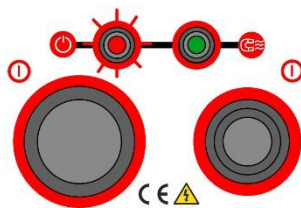
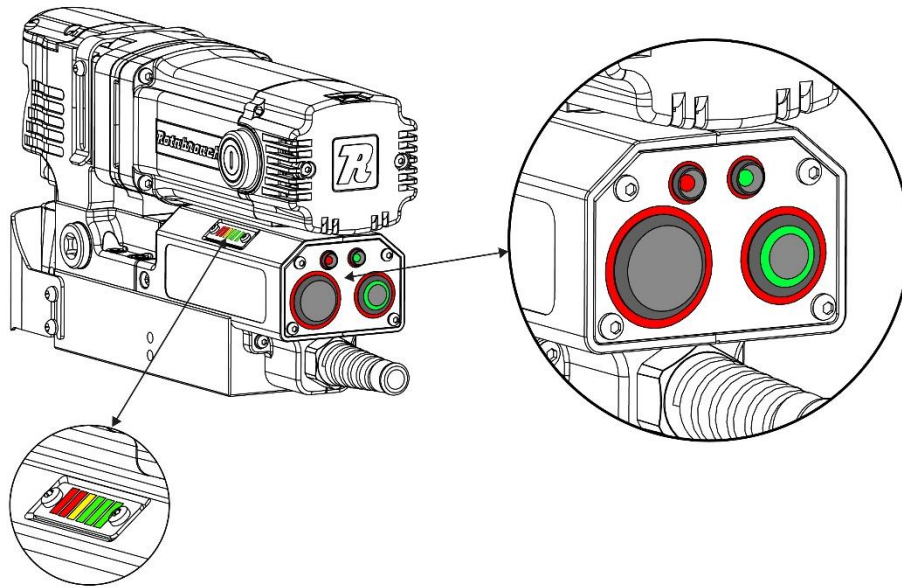

1) Power
When the drill is connected to the power supply the RED LED will indicate power to the drill.

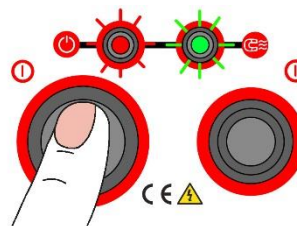

2) Magnet ON
To turn the magnet ON or OFF, press the large button on the control panel. The LED will illuminate either GREEN or RED depending on material thickness.

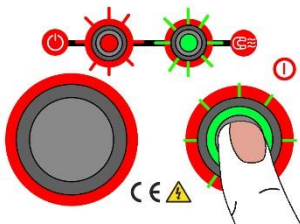

3) Motor ON
Press the GREEN switch to turn the motor on. Proceed with cutting-following all safety guidelines.

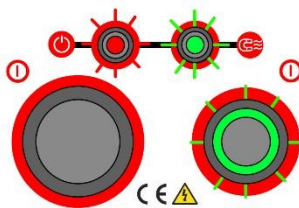

4) Cutting
See below for detailed description of the CutSmart™ visual indicator.

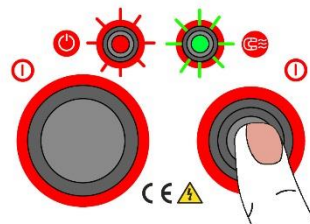

5) Motor OFF
To stop the motor press the GREEN switch. The motor will stop and the magnet will remain. The GREEN switch will turn off.

CutSmart™ Technology

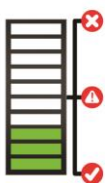

Green Zone
Perfect, try to keep in the green zone for the best cut and optimum machine performance.



Yellow Zone
A little too much pressure on the drill ease off to get back to the green zone.



Red Zone
Overload: Back off immediately as too much force will cause the motor to cut off if you continue.

CutSmart™ Technology

Designed for you to get the most out of your machine and your cutters. CutSmart has an easy to read panel that indicates when you are drilling with too much force, which will damage the machine and the cutters.

Allow the cutter to do the work and you will find that a much smoother hole and faster drilling time is achieved.

8) EXTENSION CABLE SELECTION

The machines are factory fitted with a 2-metre length of cable having three conductors 1.5mm²

LIVE, NEUTRAL and EARTH. If it becomes necessary to fit an extension cable from the power source, care must be taken in using a cable of adequate capacity. Failure to do so will result in a loss of traction by the magnet and a reduction of power from the motor.

If the replacement of the supply cord is necessary, this has to be done by the manufacturer or an approved agent in order to avoid a safety hazard.

Assuming a normal AC supply of the correct voltage, it is recommended that the following extension lengths shall not be exceeded:

For 110v supply: 3.5metres of 3 core x 1.5mm²

For 230v supply: 26metres of 3 core x 1.5mm²

ALWAYS DISCONNECT THE MACHINE FROM THE POWER SOURCE BEFORE CHANGING CUTTERS.

9) MOUNTING OF CUTTERS

- The machine has been made to accept cutters having 19.05mm (3/4") dia. Weldon shanks.

The following procedure is to be used when mounting cutters:

- Lay the machine on its side with feed handles uppermost, ensuring arbor is wound down to its lowest point to enable access to socket screws RD4066.
- Take appropriate pilot and place through the hole in cutter shank. Insert shank of cutter into bore of arbor, ensuring alignment of two drive flats with socket screws.
- Tighten both screws using hexagon key.

10) REMEDIES FOR HOLE MAKING PROBLEMS

<i>Problem</i>	<i>Cause</i>	<i>Remedy</i>
1) Magnetic base won't hold effectively	<p>Material being cut may be too thin for efficient holding.</p> <p>Swarf or dirt under magnet.</p> <p>Irregularity on magnet contact or work-piece.</p> <p>Insufficient current going to magnet during drilling cycles.</p>	<p>Attach an additional piece of metal under the magnet, or mechanically clamp magnetic base to work-piece.</p> <p>Clean magnet.</p> <p>Use extreme care; file any imperfections flush to surface.</p> <p>Confirm power supply and output from control unit, check supply cable.</p>
2) Cutter skips out of centre-punch mark at initiation of cut	<p>Magnetic base is not holding effectively.</p> <p>Worn arbor bushing and/or ejector collar.</p> <p>Too much feed pressure at start of cut.</p> <p>Cutter is dull, worn, chipped or incorrectly sharpened.</p> <p>Poor centre-punch mark; weak pilot spring; pilot not centred in centre-punch mark.</p> <p>Worn or bent pilot, worn pilot hole.</p>	<p>See causes and remedies above.</p> <p>New arbor bushing is needed.</p> <p>Light pressure only is needed until a groove is cut. The groove then serves as a stabilizer.</p> <p>Replace or re-sharpen. Sharpening service is available.</p> <p>Improve centre-punch and/or replace worn parts</p> <p>Replace part or parts</p>
3) Excessive drilling pressure required	<p>Incorrectly re-sharpened, worn or chipped cutter.</p> <p>Coming down on swarf lying on surface of work-piece.</p> <p>Swarf accumulated (packed) inside cutter.</p>	<p>Re-sharpen or replace.</p> <p>Take care not to start a cut on swarf.</p> <p>Clear cutter.</p>
4) Excessive cutter breakage	<p>Steel swarf or dirt under cutter.</p> <p>Incorrectly re-sharpened or worn cutter.</p> <p>Cutter skipping.</p> <p>Cutter not attached tightly to arbor.</p> <p>Insufficient use of cutting oil or unsuitable type of oil.</p> <p>Incorrect speed</p>	<p>Remove cutter, clean part thoroughly and replace.</p> <p>Always have a new cutter on hand to refer to for correct tooth geometry, together with instruction sheet.</p> <p>See causes and remedies (2).</p> <p>Retighten.</p> <p>Inject oil of light viscosity into the coolant-inducing ring and check that oil is being metered into cutter when pilot is depressed. If not, check pilot groove and arbor internally for dirt or apply oil externally. (Even a small amount of oil is very effective).</p> <p>Ensure correct speed is use for the cutter.</p>
5) Excessive cutter wear	<p>See cause and remedy above</p> <p>Incorrectly re-sharpened cutter.</p> <p>Insufficient or spasmodic cutting pressure.</p>	<p>Refer to instructions and a new cutter for proper tooth geometry.</p> <p>Use sufficient steady pressure to slow the drill down. This will result in optimum cutting speed and chip load.</p>

11) WIRING DIAGRAM

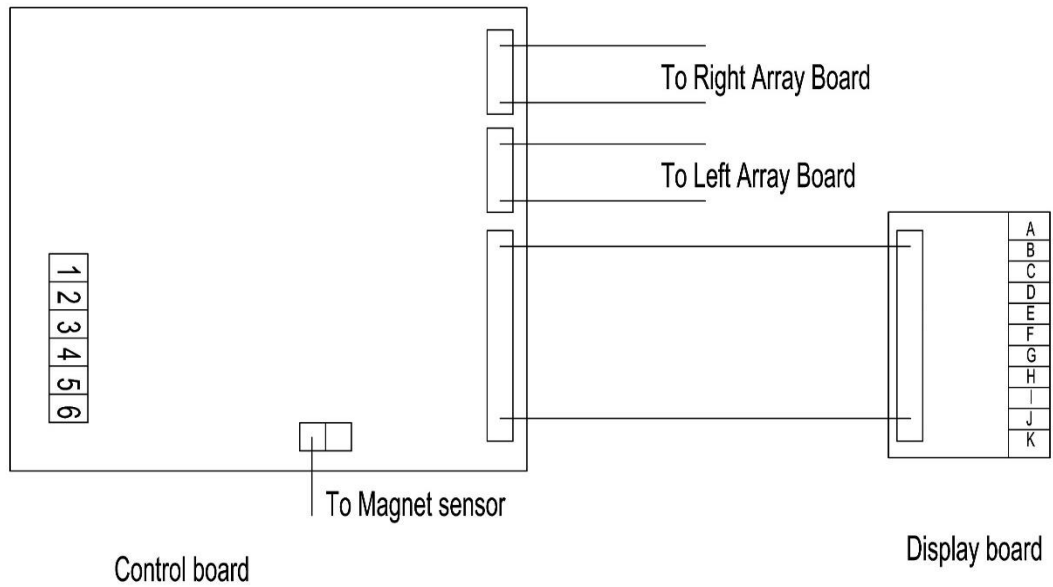

No	Function	Wire Colour
1	Magnet Negative Output	Black
2	Magnet Positive Output	Red
3	Mains Neutral Input	Blue
4	Motor Neutral Output	Red
5	Motor Live Output	Red
6	Mains Live Input	Brown

No	Function	Wire Colour
A	Motor Switch 0V	White
B	Motor Switch +5V (Green)	White
C	Magnet Switch 0V	White
D	Magnet Switch +5V	White
E	Motor LED +12V	White
F	Motor LED 0V	White
G	Magnet 'ON' LED 0V	White+ Green
H	Magnet 'ON' LED +5 V	White+Brown
I	Magnet 'ON' LED 0V	White+ Red
J	Power 'ON' LED +5V	White+Brown
K	Power 'ON' LED 0V	White+Black

12) EXPLODED VIEW OF MACHINE

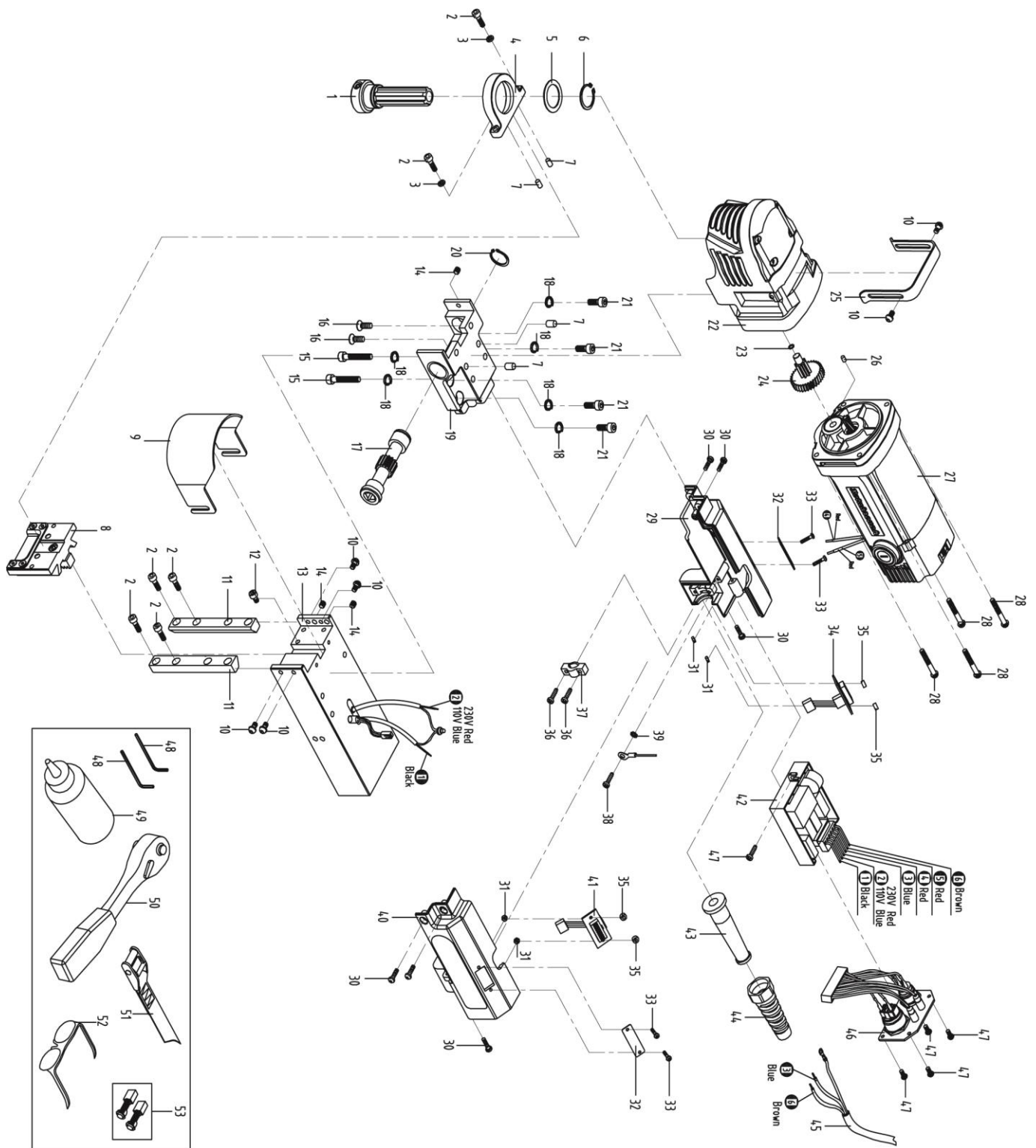

Item#	Rotabroach P/N	Description	Qty/pcs
1	RDF2000	Spindle assembly	1
2	RDF4000	Screw	6
3	RDF4001	Circlip	2
4	RDF3000	Bearing bracket	1
5	RDF4002	Gear Shaft Washer	1
6	RDF4003	Circlip	1
7	RDF4004	Straight Pin	4
8	RDF2001	Slide assembly	1
9	RDF3001	Guard	1
10	RDF4005	Screw	6
11	RDF3002	Guide Bar	2
12	RDF4006	Screw	1
13	RDF2002/3	Magnet assembly 230v	1
	RDF2002/1	Magnet assembly 110v	1
14	RDF4007	Screw	3
15	RDF4008	Screw	2
16	RDF4009	Screw	2
17	RDF3003	Capstan spindle	1
18	RDF4010	Circlip	6
19	RDF2003	Connected base assembly	1
20	RDF4011	Circlip	1
21	RDF4012	Screw	4
22	RDF2004	Gear Box assembly	1
23	RDF4013	Gear Shaft Washer	1
24	RDF2005	Shaft gear assembly	1
25	RDF3004	Handle	1
26	RDF4014	Straight Pin	1
27	RDF2006/3	Motor assembly 230v	1
	RDF2006/1	Motor assembly 110v	1
28	RDF4015	Screw	4
29	RDF2007	Right cover shell subassembly	1
30	RDF4016	Screw	6

31	RDF4017	Nut	4
32	RDF4018	Indicator light plate	2
33	RDF4019	Screw	4
34	RDF4020	Right load indicator light	1
35	RDF4021	Plastic ring	4
36	RDF4022	Screw	2
37	RDF4023	Cable Clamp	1
38	RDF4024	Screw	1
39	RDF4025	outer sawtooth washer	1
40	RDF2008/3	Left cover shell subassembly 230v	1
	RDF2008/1	Left cover shell subassembly 110v	1
41	RDF4026	Left load indicator light	1
42	RDF2009/3	PCB panel subassembly 230v	1
	RDF2009/1	PCB panel subassembly 110v	1
43	RDF4027	Cable jacket	1
44	RDF4028	Jacket	1
45	RDF2010/3	Cable Plug Assembly 230v	1
	RDF2010/1	Cable Plug Assembly 110v	1
46	RDF2011	Panel subassembly	1
47	RDF4029	Screw	5
48	RDF4030	Hexagon spanner	2
49	RDF4031	Coolant bottle	1
50	RDF4032	Ratchet handle	1
51	RD4329B	Safety rope	1
52	RDF4033	Goggles	1
53	RDF3005/3	Spare Brush 230v	1
	RDF3005/1	Spare Brush 110v	1

13) MOTOR BREAKDOWN

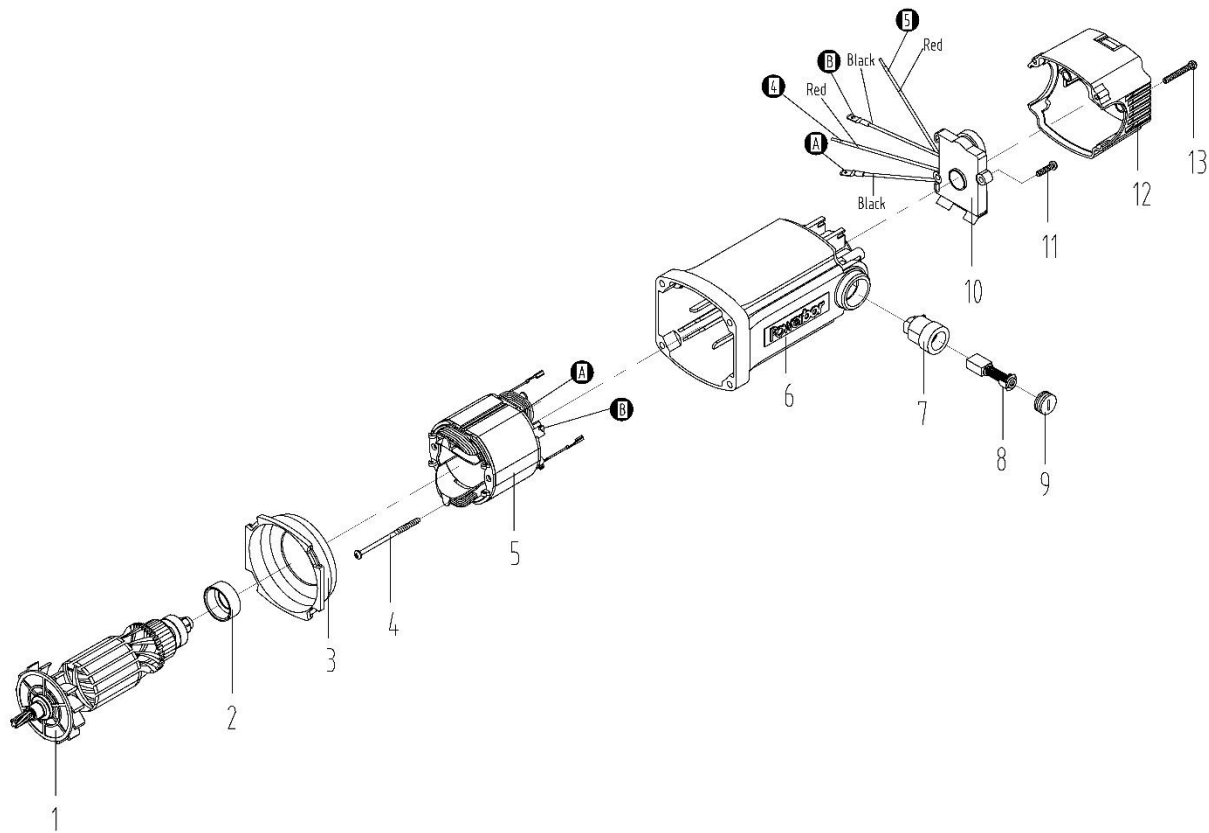

No.	Part	Description	Qty
1	RDF2021/1	Armature Assembly 110v	1
	RDF2021/3	Armature Assembly 230v	1
2	RDF3014	Bearing Sleeve	1
3	RDF3009	Field Coil Baffle	1
4	RDF4038	Field Coil Screws	2
5	RDF2019/1	Field Coil Assembly 110v	1
	RDF2019/3	Field Coil Assembly 230v	1
6	RDF3010	Motor Frame	1
7	RDF3011	Brush Holder	2
8	RDF3005/1	Carbon Brush Set 110v	1
	RDF3005/3	Carbon Brush Set 230v	1
9	RDF3012	Brush Caps	2
10	RDF2020/1	Speed Controller Assembly 110v	1
	RDF2020/3	Speed Controller Assembly 230v	1
11	RDF4040	Speed Controller Screws	2
12	RDF3013	End Cap	1
13	RDF4039	End Cap Screws	2

14)CONTROL PANEL AND PARTS LIST

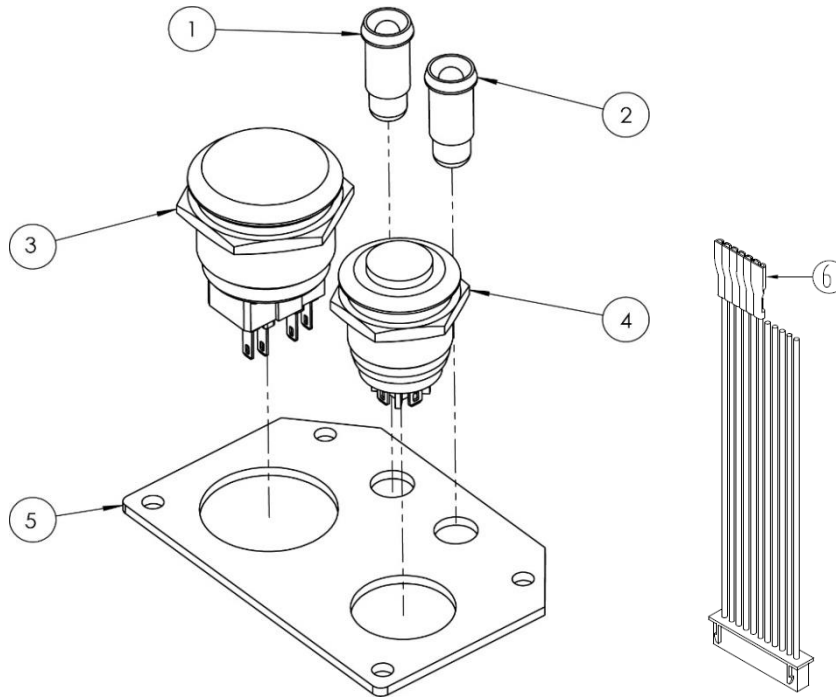

1	RDC4092	Red LED	1
2	RDC4093	Red/Green LED	1
3	RDC4091	Magnet Switch	1
4	RDA4051	Motor Switch	1
5	RDF3006	Facia Plate	1
6	RDF3017	Connection Line	1

15) PIPE ADAPTOR KIT RD2311*FITTING INSTRUCTIONS*

- Dependent upon the size of the pipe to be cut (see illustrations) attach adjustable angle plates RD3328 with cap screws RD4325 and washers RD4205 (4 off each) to the magnet sides. Do not tighten.
- Locate the machine on the centreline of the pipe taking care that the magnet is in line with the longitudinal axis of the pipe.
- Switch on the magnet and move the sliding plates down to the outside diameter of the pipe. Tighten the screws on both sides by hand then check once again that the full length of the moving plates is touching the pipe at the front and back, fasten the plate securely. Feed the safety strap through the lugs at the front of the housing, around the pipe and pull tight.
- When cutting the hole DO NOT use excessive pressure but rather let the cutter ease into the cutting surface.

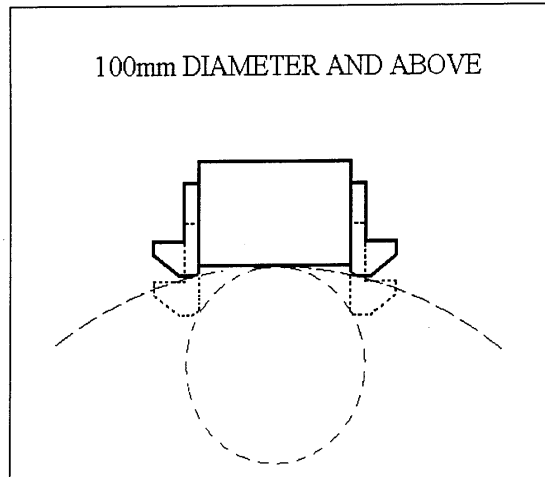
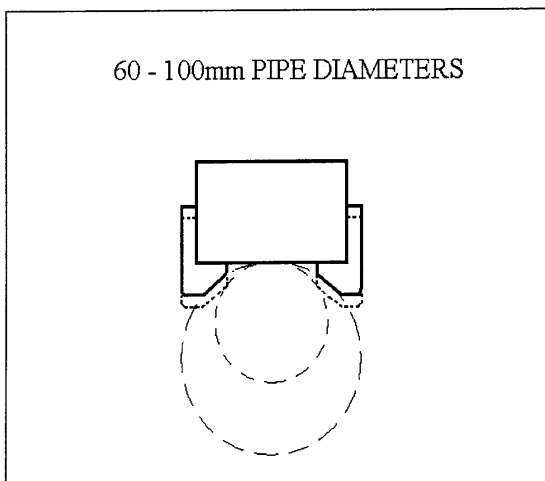

16) MAINTENANCE

In order to 'get the best life' out of your Rotabroach machine always keep it in good working order.

A number of items must always be checked on Rotabroach machines.

Always before starting any job make sure the machine is in good working order and that there are no damaged or loose parts. Any loose parts must be tightened.

Before proceeding with any maintenance work be certain that the power supply is disconnected.

Description	Every operation	1 week	1 Month
Visual check of machine for damage	X		
Operation of machine	X		
Check brush wear		X	
Check magnetic base	X		
Check grease			X
Check armature			X

Visually check the machine for damage.

The machine must be checked before operation for any signs of damage that will affect the operation of the machine. Particular notice must be taken to the mains cable, if the machine appears to be damaged it should not be used, failure to do so may cause injury or death.

Check operation of the machine.

The machines operation must be checked to ensure that all components are working correctly.

Machine Brushes - should be checked to make sure there is no abnormal wear present (this should be checked at least once a week if used frequently). If the brush has worn more than 2/3 the original length the brushes should be changed. Failure to do so may cause damage to the machine.

Magnetic base – before every operation the magnetic base should be checked to make sure that the base is flat and there is no damage present. An uneven magnet base will cause the magnet not to hold as efficiently and may cause injury to the operator.

Check machines grease.

The gearbox grease should be checked once a month to ensure all moving components are covered to prevent wear. The grease should be changed at least once a year to ensure you gain the best from your machine.

Check Armature of the machine.

This should be checked at least once a month to check that there are no visual signs of damage to the body or to the commutator. Some signs of wear will be seen on the commutator over a period of time, but this is normal (this is the part that comes into contact with the brushes) however, if there are any signs of abnormal damage the part should be replaced.

17) TROUBLE SHOOTING

Magnet and motor do not function	<ul style="list-style-type: none"> - The magnet switch is not connected to the power supply - Damaged or defective wiring - Defective magnet switch - Defective control unit - Defective power supply
Magnet does function, the motor does not	<ul style="list-style-type: none"> - Damaged or defective wiring - Carbon brushes are stuck or worn out - Defective magnet switch - Defective on / off switch - Defective control unit - Defective armature and/or field
Magnet does not function, the motor does	<ul style="list-style-type: none"> - Defective magnet - Defective control unit
Hole cutters break quickly, holes are bigger than the hole cutter	<ul style="list-style-type: none"> - Play in the guide - Bent spindle - Shaft extending from the motor is bent - Pilot bent
Motor running roughly and/or seizing up	<ul style="list-style-type: none"> - Bent spindle - Shaft extending from the motor is bent - Triangular guide not mounted straight
Motor making a rattling sound	<ul style="list-style-type: none"> - Gear ring (bottom of the armature) worn out - Gear(s) worn out - No grease in gear box
Motor humming, big sparks and motor has no force	<ul style="list-style-type: none"> - Armature damaged - Field burned - Carbon brushes worn out
Motor does not start or fails.	<ul style="list-style-type: none"> - Damaged or defective wiring - Damage to armature or field coil - Damaged or defective brushes
Insufficient magnetic force	<ul style="list-style-type: none"> - Damaged or defective wiring - Bottom of magnet not clean and dry - Bottom of magnet not flat - Work piece is not bare metal - Work piece is not flat - Work piece is too thin less than 10mm - Defective control unit - Defective magnet
Frame under voltage	<ul style="list-style-type: none"> - Damaged / defective wiring - Defective magnet - Motor seriously dirty
Fuse blows when magnet switch is turned on	<ul style="list-style-type: none"> - Damaged or defective wiring - Wrong value fuse - Defective magnet switch - Defective control unit - Defective magnet
Fuse blows when motor is started up	<ul style="list-style-type: none"> - Damaged or defective wiring - Motor running roughly - Defective armature and / or field - Carbon brushes worn out - Defective control unit
Rotation system free stroke too long	<ul style="list-style-type: none"> - Loose or defective gear-rack - Defective rotation system

18) CUTTER SELECTION AND SPEEDS

Material	Material Hardness	Cutter
Mild and free cutting steels	<700N/mm ²	RAP or RAPL
Mild and free cutting steels	<850N/mm ²	SRCV or SRCVL
Steel angle and joists	<700N/mm ²	RAP or RAPL
Steel angle and joists	<850N/mm ²	SRCV or SRCVL
Plate and sheet steel	<700N/mm ²	RAP or RAPL
Plate and sheet steel	<850N/mm ²	SRCV or SRCVL
Aluminium	<750N/mm ²	RAP or RAPL
Aluminium	<850N/mm ²	SRCV or SRCVL
Brass	<700N/mm ²	RAP or RAPL
Brass	<850N/mm ²	SRCV or SRCVL
Cast iron	<700N/mm ²	RAP or RAPL
Cast iron	<850N/mm ²	SRCV or SRCVL
Stainless steel	<700N/mm ²	RAP or RAPL
Stainless steel	<850N/mm ²	SRCV or SRCVL
Stainless steel	>850N/mm ²	CWC to CWCX
Rail track	>850N/mm ²	SCRWC or SCRWCL
Tool steel	>850N/mm ²	CWC to CWCX
Die Steel	>850N/mm ²	CWC to CWCX

The data listed below is for reference purposes only, and indicate potential starting conditions. It is the responsibility of the site operation manager to determine correct application requirements.

Material to be cut	Cutting surface speed Meters/min	Cutter diameter/Material/RPM relationship															
		13		14		18		22		30		50		65			
		L	U	L	U	L	U	L	U	L	U	L	U	L	U		
Aluminium	60 - 90	1469	2203	1364	2046	1061	1591	868	1302	637	955	382	573	294	441		
Brass & Bronze	40 - 50	979	1224	909	1137	707	884	579	723	424	530	255	318	196	245		
Iron: cast(soft)	30 - 50	734	1224	682	1137	530	884	434	723	318	530	191	318	147	245		
cast(hard)	15 - 21	367	514	341	477	265	371	217	304	159	223	95	134	73	103		
cast(malleable)	15 - 30	367	734	341	682	265	530	217	434	159	318	95	191	73	147		
Steel: mild	24 - 30	588	734	546	682	424	530	347	434	255	318	153	191	118	147		
high tensile	3 - 5	73	122	68	114	53	88	43	72	32	53	19	32	15	24		
stainless (free cutting)	15 - 18	367	441	341	409	265	318	217	260	159	191	95	115	73	88		
stainless (heat resisting)	6 - 13	26	318	136	296	106	230	87	188	64	138	38	83	29	64		

These are only starting points. They will vary with application and work piece condition.

Material or Application Type	Feed Per Tooth (mm)
Thin Walled Workpieces Oblique Entry / Curved Surfaces Semi-Circles / Fragile Setups	.0254 / .0508 (.0762 FPT with Work Hardening Materials)
Soft / Gummy Materials	.1016 / .127
Typical / Average Applications	.0762 / .1016
Deep Holes	.1016 / .127

Difficult-to-machine materials will require reduced feed rates.

RotabroachTM

19) WARRANTY AND CE STATEMENTS

RotabroachTM warrants its machines to be free from faulty materials, under normal usage of machines, for a period of 12 months from initial date of purchase. All other parts (excluding cutters) are under warranty for 90 days, provided that the warranty registration card (or online registration) has been completed and returned to RotabroachTM or its designated distributor within a period of (30) days from the purchase date. Failure to do so will void the warranty. If the stated is adhered to RotabroachTM will repair or replace (at its option) without charge any faulty items returned.

This Warranty does not cover:

1. Components that are subject to natural wear and tear caused by the use not in accordance with the operator's instructions
2. Defects in the tool caused by non-compliance with the operating instructions, improper use, abnormal environment conditions, inappropriate operating conditions overload or insufficient servicing or maintenance.
3. Defects caused by using accessories, components or spare parts other than original RotabroachTM parts.
4. Tools to which changes or additions have been made.
5. Electrical components are subject to manufacturer's warranty.

Your online registration can be submitted at www.rotabroach.co.uk

The warranty claim must be logged within the warranty period. This requires the submission or sending of the **complete** tool in question with the original sales receipt which must indicate the purchase date of the product. A complaint form must also be submitted prior to the return.

This can be found online at www.rotabroach.co.uk. Failure to complete this form will result in the delay of your claim.

All goods returned defective must be returned pre-paid to RotabroachTM, in no event shall Rotabroach[®] be liable for subsequent direct, or indirect loss or damage.

THIS WARRANTY IS IN LIEU OF ANY OTHER WARRANTY, (EXPRESSED OR IMPLIED) INCLUDING ANY WARRANTY OF MERCHANTABILITY OR FITNESS FOR A PARTICULAR PURPOSE. ROTABROACHTM RESERVE THE RIGHT TO MAKE IMPROVEMENTS AND MODIFICATIONS TO DESIGN WITHOUT PRIOR NOTICE

Known and Trusted Worldwide for Quality, Performance and Reliability