

Weldability

AN INTRODUCTION TO TIG WELDING

wws group | support@weldability.com

WARNING:

This document contains general information about the topic discussed herein. This document is not an application manual and does not contain a complete statement of all factors pertaining to that topic.

The installation, operation and maintenance of arc welding equipment and the employment of procedures described in this document should be conducted only by qualified persons in accordance with applicable codes, safe practices, and manufacturers' instructions.

Always be certain that work areas are clean and safe and that proper ventilation is used. Misuse of equipment, and failure to observe applicable codes and safe practices can result in serious personal injury and property damage.

General Principles

TIG (Tungsten Inert Gas) welding also known as GTA (Gas Tungsten Arc) in the USA and WIG (Wolfram Inert Gas) in Germany, is a welding process used for high quality welding of a variety of materials, especially, Stainless Steel, Titanium and Aluminium.

Equipment

- DC or AC / DC Power Source
- TIG Torch
- Work Return Welding Lead
- Shielding gas supply line, (normally from a cylinder)
- Foot Control Unit (common option)

Power Source

TIG welding can be carried out using DC for Stainless Steel, Mild Steel, Copper, Titanium, Nickel Alloys etc and AC for Aluminium and its Alloys and Magnesium. Further information on the TIG Welding Process follows information on equipment used in this document.

The Power Source is of a transformer design with or without a rectifier, with a drooping characteristic (constant current power source).

The output is generally controlled by either a moving core within the main transformer of the power source or by using electronic control of power thyristors.

DC power sources could be of 1 phase or 3 phase design, with an inductor to provide a smooth output. AC and AC / DC Power Sources are of a single phase design.

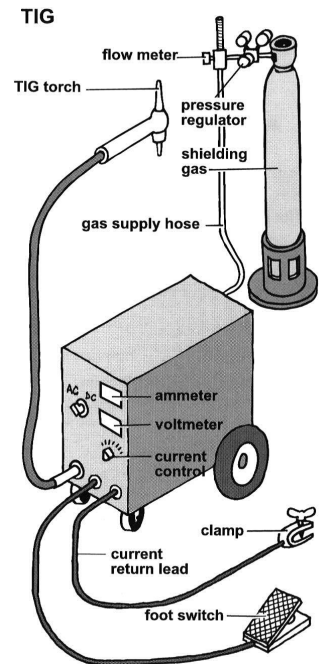

a typical TIG welding setup

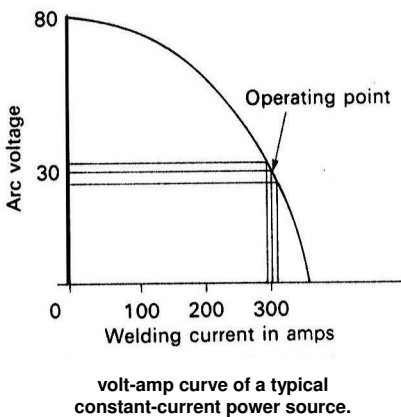

Other important functions in TIG power sources are...

Arc Starting Circuit

HF : - Sparks of high tension jump across the gap between electrode and workpiece rapidly to carry the welding current across to start welding in DC TIG welding, this will stop once the arc is struck, in AC TIG welding, this will normally continue to keep the arc alive as the AC output changes from a Positive half cycle to a Negative half cycle and back again.

Lift Arc : - The electrode is touched onto the workpiece, the TIG Torch switch or foot control switch is operated, the equipment circuits detect a short circuit on the output and allow only a very low current typically 5 - 8 amps to flow. The electrode is lifted off the workpiece, the equipment circuits now detect a voltage between electrode and workpiece and welding current strikes across that very tiny gap as the electrode lifts off and welding continues.

Scratch Start : - The electrode is scratched or dragged and lifted off the workpiece, much the same as striking an electrode in MMA (Stick) welding.

Using the HF method. No cross contamination from electrode and workpiece takes place as they never touch, with Lift arc correctly set and used, only minimal cross contamination occurs because of the low current when electrode is in contact with workpiece, scratch start TIG is a low cost option for general TIG welding, but cross contamination can occur.

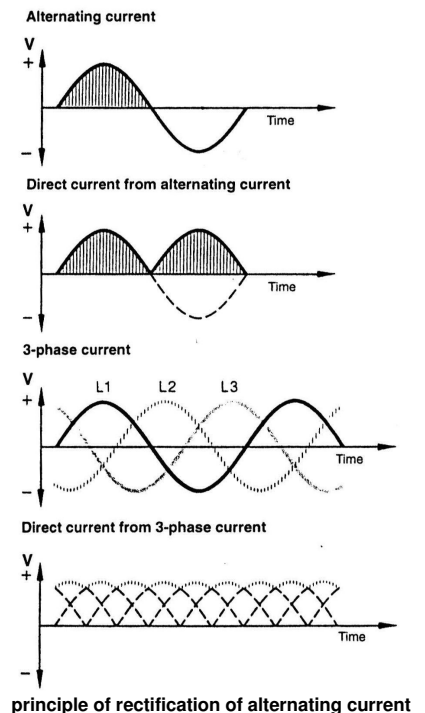

Output Control

In TIG output voltage is not controlled by the power source (as with MIG), but is determined by the process and output welding current. Welding current is normally controlled by either a moving core in the main transformer or by electronic power components.

Moving Core Control : - The main drawback of this method of control, is its slow response to change when required and due to the mechanical movement remote controls (such as foot control) are so difficult and expensive to provide, that it is thought of as not possible.

Electric Power Control : - This system has many advantages over the previous system. The possibility to have a remote control of welding current, so the operator can raise or lower the output as required while welding.

Craterfil / Slopedown Control

If not using a remote control, but simply a torch ON / OFF switch the output can be sloped down to finish the weld without a crater at the end of the molten pool, an electronic timer gradually reduces the output from welding valve to off over an adjustable time.

AC Waveform Balance

A pot can be fitted, when welding in AC mode the positive half cycle cleans the oxides on the Aluminium and the Negative half cycle produces weld penetration during welding self rectification occurs and causes an imbalance of the waveform, a balance control allows the operator to adjust the amount of time the cleaning or penetration takes in each cycle.

Gas Flow Control

The TIG process relies entirely on the shielding gas to protect the hot electrode and molten pool and it is therefore essential for good arc striking that the flow of gas is initiated and allowed to stabilise before the arc is struck. Preflow timers are commonly fitted to better TIG power sources.

Equally the gas shield must be allowed to flow after the arc is extinguished, to prevent oxidation of the electrode and cooling weld. Postflow timers are fitted to most TIG power sources.

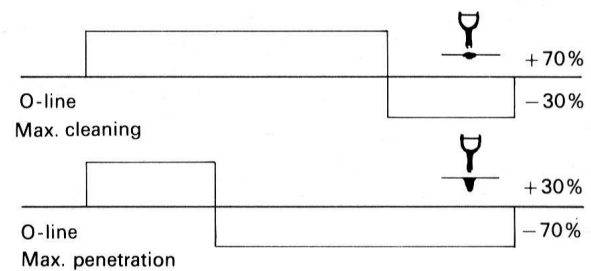

the effects of altering the AC wave-form balance

DC Output Pulse Control

For DC welding use, there is often a pulsing facility which allows the welding current to be switched between a low current (say approximately 15 amps), sufficient to keep the arc alight but not produce much heat and the main pulse current (say 50 - 350 amps), dependant on the design control of the following parameters can be adjusted to provide high quality welding.

- Peak Current Value
- Peak Time
- Base Current Value
- Base Current Time
- Frequency of Pulses

The use of pulsed current greatly extends the control which can be exercised on the process allowing:

- * Improved consistency in the under head of unbacked butt welds.
- * The ability to overcome differences in heat sink and therefore to join thick to thin material.
- * The ability to make cylindrical or circular welds without a build up of heat and an increase in weld width.
- * The ability to produce stable TIG welds at very low level.

Basically a series of overlapping spot welds, with short cooling periods between such welds.

TIG Torch

The TIG torch can be air cooled or water cooled and of vastly different shapes and sizes dependant on access to the area to be welded and welding current required.

TIG torch for use on equipment without a electric operated valve (normally scratch start systems) can have a finger operated gas valve fitted to the torch head.

If the operator is using a foot control unit, the torch will not need a switch fitted. For welding in difficult to get to areas, a flexible head torch can be used and bent to the best position for welding.

In water cooled torches, the current cable is a bore copper conductor within a water carrying hose, this means the conductor can be greatly reduced in size and weight.

The gas shield are now invariably alumina ceramics and are available in a wide range of sizes.

When access is difficult, it may be necessary to project the electrode well beyond the end of the gas nozzle, this may result in inferior gas shielding because of turbulence. This can usually be overcome by employing a Gas Lens System replacing the standard collet and collet body system, this producing improved directional and stability of the gas flow.

Connection to the power source can be via a special lug if the equipment has a stud output fitting, or a universal dinse type TIG adaptor if output fittings are dinse type sockets.

Electrodes for TIG welding are Pure Tungsten or a Tungsten oxide, generally 2 % Thoriated tungsten are used for DC welding and 2 % Zirconiated tungsten are recommended for AC welding. The diameter of the electrode is chosen to match the current required.

For DC welding, a sharp point is required but for AC welding only, a small bevel is needed as the end of the electrode becomes rounded when the arc is operated.

Shielding Gas

The most commonly used gas for TIG welding is argon which can be used on all metals. Argon - Hydrogen mixtures containing 2 - 5 % Hydrogen are frequently used for stainless steel and nickel-base alloys having the advantage of producing cleaner welds, giving deeper penetration.

Helium - Argon mixtures give deeper penetration, greater heat input and therefore faster welding because of the higher arc voltage than pure Argon, but arc striking may be more difficult than in Argon. These mixtures can be used for Aluminium and Copper Alloys.

Welding Process

In most Arc welding processes, the arc is struck from a consumable electrode to the workpiece and metal has been melted from electrode, transferred across the arc and finally incorporated into the molten pool. TIG process employs on electrode made from high melting point metal, usually a type of TUNGSTEN, which is not melted.

The electrode and the molten pool is shielded from the atmosphere by a stream of inert gas which flows around the electrode and is directed onto the workpiece by a nozzle which surrounds the electrode.

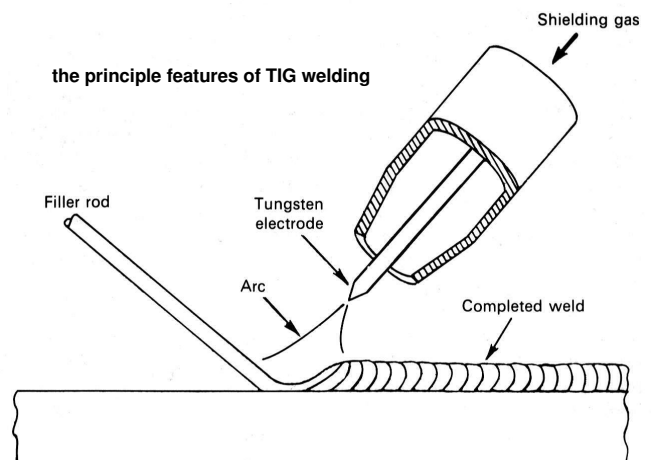

In TIG welding, the primary functions of the arc is to supply heat to melt the workpiece and any filler metal which may

be necessary. This filler metal is fed manually into the molten pool at its leading edge.

The second function of the arc is to clean the surface of the molten pool and the immediately surrounding parent metal of surface oxide films and therefore no flux is required.

The shielding gas MUST be inert with respect to the tungsten electrode and the choice is therefore more limited than with the MIG process.

When using DC the DCEN electrode negative polarity is almost invariably employed, (if DCEP is used most of the heat is in the electrode not the workpiece, so if this polarity is used, very much larger electrodes MUST be used).

The cleaning function of the arc does not take place on the DCEN polarity, so metals forming refractory oxide surface films such as aluminium cannot be readily welded on this polarity.

For Aluminium the electrode positive polarity on which cleaning takes place, would therefore appear desirable. In fact on this polarity, more energy is dissipated at the electrode which therefore becomes overheated.

Aluminium is therefore welded using AC and the cleaning action takes place on the electrode positive half cycles and weld penetration takes place on the electrode negative half cycle.

Zirconiated tungsten electrodes are used for AC welding because Zirconia helps the electrode to maintain the desired stable end.

Optimum Process Variables

<u>Tungsten</u>	<u>TIG Process</u>	<u>Suitable Metals</u>
1 – 2% Thoriated Tungstens	Used mainly in DCEN, but possible with DCEP.	Ferrous materials and some non-ferrous, excluding aluminium and magnesium.
Zirconiated Tungstens	Used mainly in AC, but possible in DC with DCEN or DCEP.	Aluminium, magnesium and alloys of these materials.

Maximum Tungsten Current Ratings

Electrode Diameter (mm)	Maximum Current-Carrying Capacity (in amps)			B. S Recommendations for Class 1 Welds.
	Thoriated		Zirconiated	Zirconiated
	D.C	A.C	A.C	A.C (With Suppressor)
0.8	45	30	-	-
1.2	70	40	40	-
1.6	145	55	55	50
2.4	240	90	90	80
3.2	380	140	150	120
4.0	440	195	210	160
4.8	500	250	275	200
5.6	-	275	320	250
6.4	-	320	370	320
7.9	-	410	-	-
9.5	-	500	-	-

Optimum Tungsten Current Ratings

		Optimum Current Ranges – In Amps			
Diameter (in)	Diameter (mm)	DCSP Argon	DCRP Argon	ACHF Argon	AC Balanced Argon
2% THORIUM ALLOYED TUNGSTEN					
0.20"	0.5	15-40	-	15-35	5-20
0.40"	1.0	25-85	-	20-80	20-60
1/16"	1.6	50-160	10-20	50-150	60-120
3/32"	2.4	135-235	15-30	130-250	100-180
1/8"	3.2	250-400	25-40	225-360	160-250
5/32"	4.0	400-500	40-55	300-450	200-320
3/16"	4.8	500-750	55-80	400-550	290-390
1/4"	6.4	750-1000	80-125	600-800	340-525
Optimum Current Ranges – In Amps					
Diameter (in)	Diameter (mm)	DCSP Argon	DCRP Argon	ACHF Argon	AC Balanced Argon
ZIRCONIUM ALLOYED TUNGSTEN					
0.20"	0.5	-	-	15-35	5-20
0.40"	1.0	-	-	20-80	20-60
1/16"	1.6	-	-	50-150	60-120
3/32"	2.4	-	-	130-250	100-180
1/8"	3.2	-	-	225-360	160-250
5/32"	4.0	-	-	300-450	200-320
3/16"	4.8	-	-	400-550	290-390
1/4"	6.4	-	-	600-800	340-525

Selection of Welding Variables for Specific Joint Preparations

Material	Thickness (mm)	Current (Amps)	Type Of Power	Argon Flow (l./min)	Electrode Dia. (mm)	Nozzle Bore (mm)	No. of Passes	Prep Type (see below)
Stainless, heat and corrosion resistant	1.2	40-60	d.c or a.c	2.5	1.6 or 2.4	6	1	S.E.C.B
	1.6	60-80	d.c or a.c	3.0	2.4	10	1	S.E.C.B
	2.0	80-90	d.c or a.c	3.3	1.6 or 2.4	10	1	S.E.C.B
	2.6	90-110	d.c	3.5	2.4	10	1	S.E.C.B
	3.2	110-130	d.c	4.0	2.4 or 2.4 or 3.2	10 or 12	1	S.E.O.B or S.V.C.B 80°
	4.8	130-170	d.c	4.0	3.2	10 or 12	1	S.V.C.B 80°
Aluminium and alloys	1.2	60-70	a.c	3.3	2.4	10	1	S.E.C.B
	1.6	70-90	a.c	4.7	2.4	10	1	S.E.C.B
	2.0	90-110	a.c	4.7	3.2	12	1	S.E.C.B
	2.6	110-130	a.c	5.0	3.2	12	1	S.E.C.B
	3.2	130-150	a.c	6.0	3.2	12	1	S.E.C.B
	4.8	130-150	a.c	7.0	4.8	12	1	S.E.C.B
		150-200						
		200						

Selection of Welding Variables TIG Welding Mild Steel

MILD STEEL -- MANUAL WELDING -- DIRECT CURRENT -- DCEN POLARITY						
Metal Thickness	Joint Type	Tungsten Diameter	Filler Rod Diameter	Amperage	GAS	
					Type	Flow-CFH
1.6mm	Butt Lap Corner Fillet	1.6mm	1.6mm	60-70	Argon	15
				70-90		15
				60-70		15
				70-90		15
3.2mm	Butt Lap Corner Fillet	1.6mm or 2.4mm	2.4mm	80-100	Argon	15
				90-115		15
				80-100		15
				90-115		15
4.8mm	Butt Lap Corner Fillet	2.4mm	3.2mm	115-135	Argon	20
				140-165		20
				115-135		20
				140-170		20
6.3mm	Butt Lap Corner Fillet	3.2mm	4.0mm	160-175	Argon	20
				170-200		20
				160-175		20
				175-210		20

Selection of Welding Variables TIG Welding Stainless Steel

STAINLESS STEEL -- MANUAL WELDING -- DIRECT CURRENT -- DCEN POLARITY						
Metal Thickness	Joint Type	Tungsten Diameter	Filler Rod Diameter	Amperage	GAS	
					Type	Flow-CFH
1.6mm	Butt Lap Corner Fillet	1.6mm	1.6mm	40-60	Argon	15
				50-70		15
				40-60		15
				50-70		15
3.2mm	Butt Lap Corner Fillet	1.6mm or 2.4mm	2.4mm	65-85	Argon	15
				90-110		15
				65-85		15
				90-110		15
4.8mm	Butt Lap Corner Fillet	2.4mm	3.2mm	100-125	Argon	20
				125-150		20
				100-125		20
				125-150		20
6.3mm	Butt Lap Corner Fillet	3.2mm	4.0mm	135-160	Argon	20
				160-180		20
				135-160		20
				160-180		20

Selection of Welding Variables TIG Welding Aluminium

ALUMINIUM -- MANUAL WELDING -- ALTERNATING CURRENT -- HIGH FREQUENCY						
Metal Thickness	Joint Type	Tungsten Diameter	Filler Rod Diameter	Amperage	GAS	
					Type	Flow-CFH
1.6mm	Butt Lap Corner Fillet	1.6mm	1.6mm	60-85	Argon	10
				70-90		10
				60-85		10
				75-100		10
3.2mm	Butt Lap Corner Fillet	2.4mm or 3.2mm	2.4mm	125-150	Argon	15
				130-160		15
				120-140		15
				130-160		15
4.8mm	Butt Lap Corner Fillet	3.2mm or 4.0mm	3.2mm	180-225	Argon	15
				190-240		15
				180-225		15
				190-240		15
6.3mm	Butt Lap Corner Fillet	4.0mm or 4.8mm	4.8mm	240-280	Argon	20
				250-320		20
				240-280		20
				250-320		20

Visual Reference Of Joint Preparation Types

For use with above welding variable tables

