



Magswitch Technology, Inc.
1355 Horizon Avenue
Lafayette, CO 80026
Magswitch.com.au
303-468-0662

Magswitch 300 Amp Finned Magnetic Ground Clamp

P/N: 8100746

The Magswitch finned magnetic ground clamps let welders quickly set up, weld and move on to the next job. Simply place it on a clean work surface, turn it on and start welding. Instant ground on a flat surface or a pipe. The finned design lowers the temperature of the unit by almost 27%.

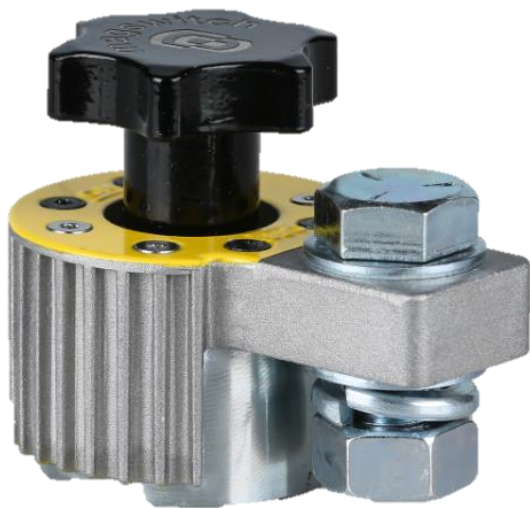

WARNING!
Do Not Operate Unless In
Contact With Ferrous Target

SPECIFICATIONS	
P/N: 8100746 - MAGSWITCH 300 Amp Finned Magnetic Ground Clamp	
Magnet Strength	90 lbs/40 kg
Net Weight	0.8 lbs/0.4 kg
Overall Height	57.3 mm
Magnetic Pole Footprint	40mm Diameter

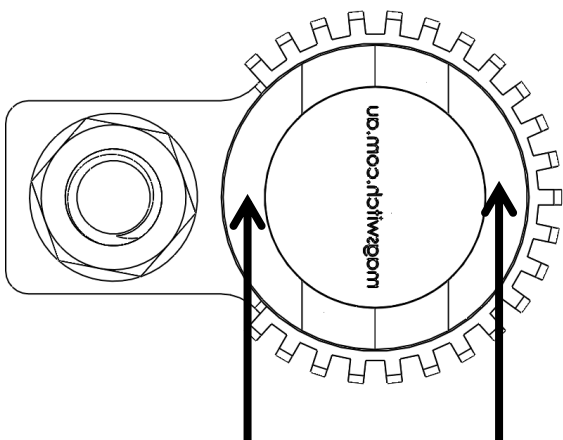

WORKING SURFACE



Part Number 1101142
Revision Date: April 30 2015

