

As a manufacturer and distributor of ceramics, Gullco can provide you with a KATBAK® ceramic weld backing to meet your needs. To maximize the benefits of your KATBAK® ceramic use in combination with the KAT® weld automation carriage.



**KATBAK® CERAMIC FEATURES AND BENEFITS:**

- A microprocessor controlled gas furnace ensures even temperature control during baking of the ceramics insuring none of the ceramics are under or, over baked
- A fume test has been done on the adhesive tape. A copy is on Share File. This test is very important for health and safety.
- Gullco does NOT use any dangerous components in our ceramics that could cause health issues.
- Gas holes allow tape to stay in contact with plate holding ceramic tight to the plate being welded.
- Gullco uses a 4" wide tape which provides superior adhesion to competitive tapes
- A raise centering aid helps placement and alignment of the ceramic over the joint.
- Ceramics come with radiused segments to allow better contact with the material.
- Gullco provides ceramic in 30 foot boxes or slightly more to allow for less waste and are packaged in vacuum sealed bags for longer shelf life. 13) Gullco ceramics are high density ceramics, baked at high temperature to offer the best heat absorption for ensuring excellent quality welds.

KAT, KBM, MOGGY, KATBAK & SAM are registered trademarks of Gullco Enterprises Limited

Distributed by:

SPECIFICATIONS ARE SUBJECT TO CHANGE WITHOUT NOTICE. ALL DIMENSIONS ARE NOMINAL

<b>GULLCO</b>		
<b>CANADA - GULLCO INTERNATIONAL LIMITED</b>		
Phone: 1-905-953-4140	Fax: 1-905-953-4138	e-mail: sales@gullco.com
<b>U.S.A - GULLCO INTERNATIONAL INC.</b>		
Phone: 1-440-439-8333	Fax: 1-234 808-4146	e-mail: ussales@gullco.com
<b>EUROPE - GULLCO INTERNATIONAL (U.K.) LIMITED</b>		
Phone: +44 1257-253579	Fax: +44 1257-254629	e-mail: uksales@gullco.com
<b>AUSTRALIA - GULLCO INTERNATIONAL PTY LIMITED</b>		
Phone: 61 (0)7 3348 5515	Fax: 61 (0)7 3348 5510	e-mail: ausales@gullco.com
<b>INDIA - GULLCO INTERNATIONAL INDIA PVT LIMITED</b>		
Phone: +91-20-2551-1433	Fax: +91-20-2551-1433	e-mail: indsales@gullco.com
<b>CHINA - GULLCO INTERNATIONAL SHANGHAI LIMITED</b>		
Phone: +8621-50460341	Fax: +8621-50463554	e-mail: c.zhang@gullco.com
<b>SINGAPORE - GULLCO INTERNATIONAL LIMITED</b>		
Phone: +65-9385-4468		e-mail: benny.lim@gullco.com
<b>LATIN AMERICA - GULLCO INTERNATIONAL LIMITED</b>		
Phone: 55-11-99485-1336		e-mail: rogerio.macedo@gullco.com
<b>GERMANY - ms gmbh Melchior Schweißtechnik</b>		
Phone: +49(0)173 5437722	Fax: +49(0)208 999 38-38	e-mail: christian.mertens@ms-gmbh.com

**WELDING AND CUTTING AUTOMATION**



CERAMIC WELD BACKING TAPE - KATBAK®

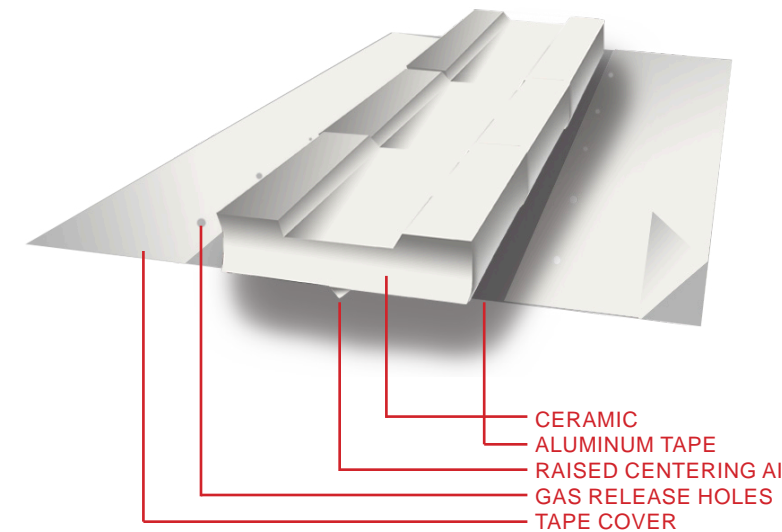

- Impart x-ray quality back beads on the root pass.
- Weld one side only
- Deposit more weld metal
- Eliminate defects and rework
- Eliminate costly unnecessary gouging and grinding
- Industry first, raised centering aid makes aligning and applying the ceramic quicker and more accurate
- Size 1/4" (6.3 mm) to 2" (51 mm) special sizes and configurations available
- Conveniently packaged and sealed in plastic for moisture proof protection
- Industry leading 4" heat receptive pressure sensitive foil for improved adhesion to work piece



TANK BUILDING



PIPE WELDING



SHIP BUILDING



INFRASTRUCTURE

*Gullco does not use any dangerous components in our ceramics*  
 IMPROVE WELD QUALITY AND REDUCE COST WITH KATBAK® CERAMIC WELD BACKING



KATBAK® Ceramic Weld Backing Improves Weld Quality, Saves Time and Reduces Cost

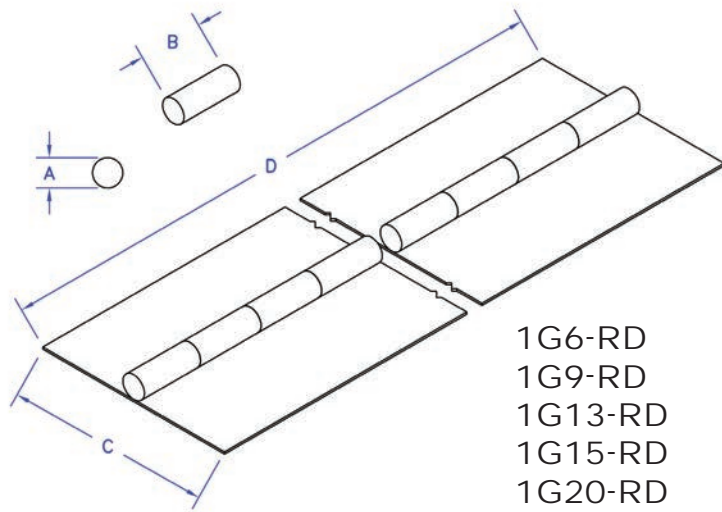

A	1G6-RD	1/4	6mm
	1G9-RD	3/8	9 mm
	1G13-RD	1/2	13mm
	1G15-RD	5/8	15mm
	1G-20RD	7/8	20mm
B		1"	25.4 mm
C		3" Tape	76.2 mm
D		24"	609.6 mm

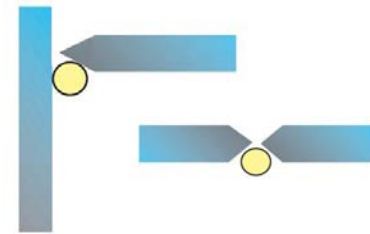

1G6-RD  
1G9-RD  
1G13-RD  
1G15-RD  
1G20-RD

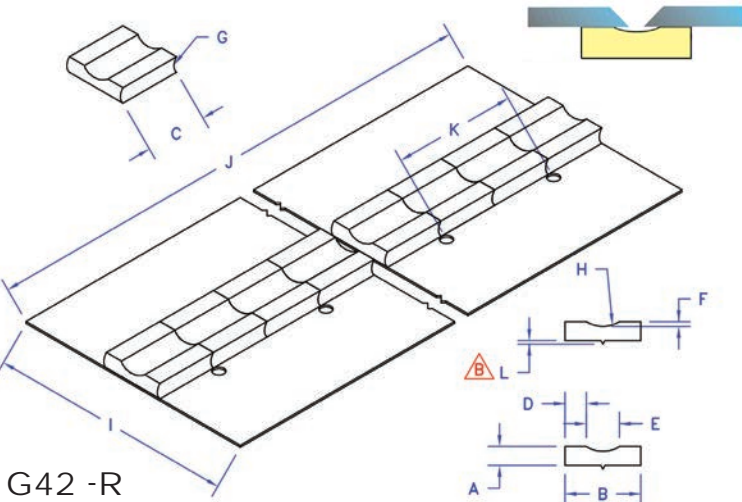

A	1/4"	6.35 mm
B	1"	25.4 mm
C	1" Min.	25.4 mm
D	9/32"	7.14 mm
E	7/16"	11.11 mm
F	1/16"	1.58 mm
G	3/16" Radius	4.76 mm
H	13/32" Radius	10.31mm
I	4" Tape	101.60 mm
J	24" Overall	609.60 mm
K	2"	50.80 mm
L	3/64"	1.2 mm

1G42 -R

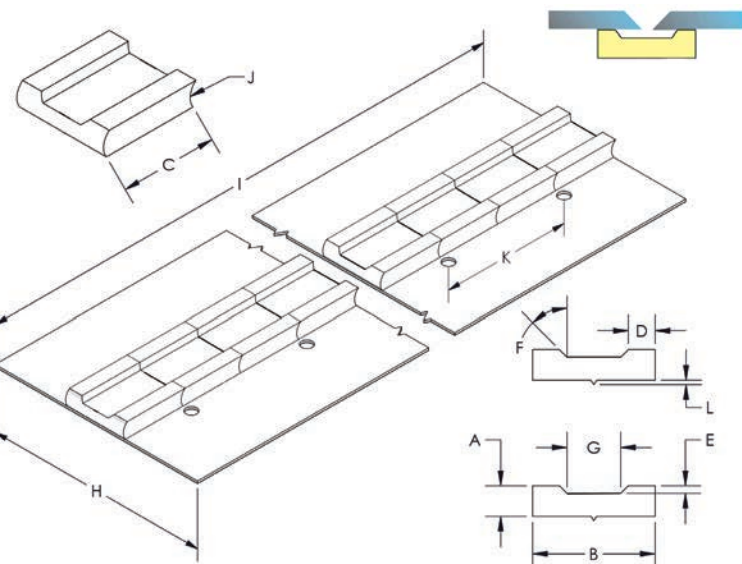

A	5/16" MIN.	[7.93mm]
B	7/8" Min. - 1" Max.	(22-25mm)
C	1"	(25.4mm)
D	5/32" (Ref.)	(3.96mm)
E	1/16"	(1.58mm)
F	45 °	45 °
G	7/16"	(11.11mm)
H	4" MIN.	(101.6mm)
I	24" Overall	(609.6mm)
J	3/16" Radius	(4.76mm)
K	2"	(50.80 mm)
L	3/64"	(1.2 mm)

1G93-R

\* Available in 1/4" to 2" (6.3 mm to 50.8 mm) tiles

KATBAK® Ceramic Weld Backing Can Lay Root Weld & Fill In One Pass With X-Ray Quality Back Beads

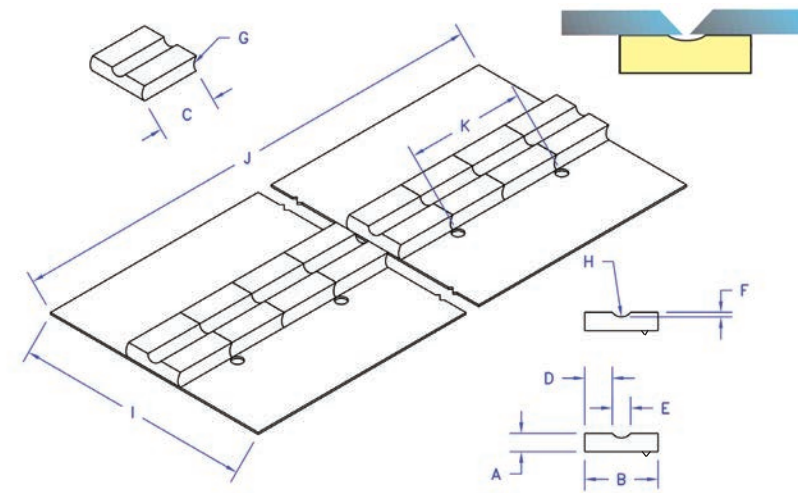

1G43-R

A	1/4"	6.35 mm
B	1"	25.4 mm
C	1" Min.	25.4 mm
D	3/8"	9.52 mm
E	1/4"	6.35 mm
F	1/16"	1.58 mm
G	3/16" Radius	4.76 mm
H	5/32" Radius	3.96 mm
I	4" Tape	101.60 mm
J	24" Overall	609.60 mm
K	2"	50.80 mm
L	3/64"	1.2 mm

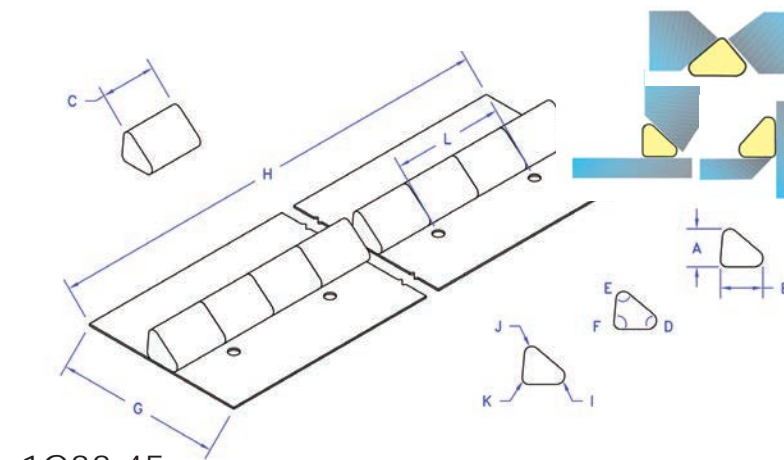

1G33-45  
1G33-60  
1G33-90

A	1/4"	6.35 mm
B	1"	25.4 mm
C	1" Min.	25.4 mm
D	3/8"	9.52 mm
E	1/4"	6.35 mm
F	1/16"	1.58 mm
G	3/16" Radius	4.76 mm
H	5/32" Radius	3.96 mm
I	4" Tape	101.60 mm
J	24" Overall	609.60 mm
K	2"	50.80 mm
L	3/64"	1.2 mm

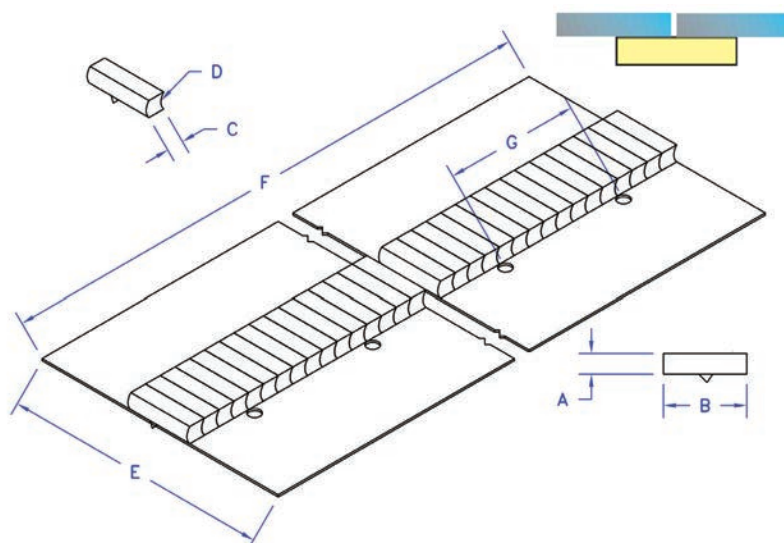

1G42-FR-1/4

A	1/4"	6.35 mm
B	1"	25.4 mm
C	1/4" Min.	6.35 mm
D	3/16" Radius	4.76 mm
E	4" Tape	101.6 mm
F	24" Overall	609.6 mm
G	2"	50.8 mm

\* Available in 1/4" to 2" (6.3 mm to 50.8 mm) tiles