

Mobile Filter Units

MaxiFil Clean

Art. No.: 67 150 103



Technical Data

Filter	
Filter stages	2
Filter method	Cleanable filter
Filter cleaning method	Rotating nozzle
Filter surface	15 m ²
Type of filter	Filter cartridge
Filter material	ePTFE membrane
Filter efficiency	> 99,9 %
Dust classification	M
Additional filters	Cyclone pre-filter
Basic data	
Extraction capacity	1100 m ³ /h
Dimensions (w x t x h)	810 x 940 x 1350 mm
Weight	206 kg
Motor power	1,5 kW
Power supply	3 x 400 V / 50 Hz
Rated current	3,2 A
Control voltage	24 V, DC
Noise level	72 dB(A)
Additional information	
IFA-Certification	W3-Approved
Fan type	Radial fan
Compressed air supply	5 - 6 bar
Quantity of extraction arms	1
Exhaust arm type	rigid metal tube arm
Diameter extraction arm	150 mm
Length of exhaust arm	2 m

Applications

- Suitable for all materials, including high-alloy steel
- High levels of smoke and particles
- Non-stop operation

Benefits

- Safe operation by rotation field control
- Exhaust arm requires less adjustment due to flow-optimised exhaust hood design
- Increased safety due to filter monitoring
- Increased safety by means of automatic dust removal in cartridges, contamination-free
- Very economic due to long lasting high capacity filters

Properties

- Automatic filter cleaning
- Exhaust arm up to 4 m
- Cleanable filter
- Automatic dust removal - contamination-free
- Rotating exhaust hood
- Spark separator

Accessories

- Automatic start-stop
- Workplace lighting incl. on/off switch at the hood



Suitable for alveole exchangeable dusts
separation > 99 % of particles < 0,4 µm



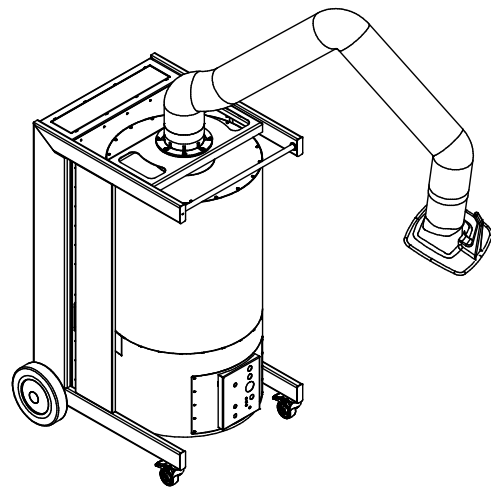
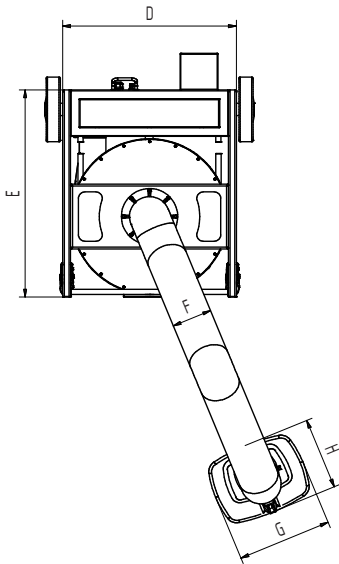
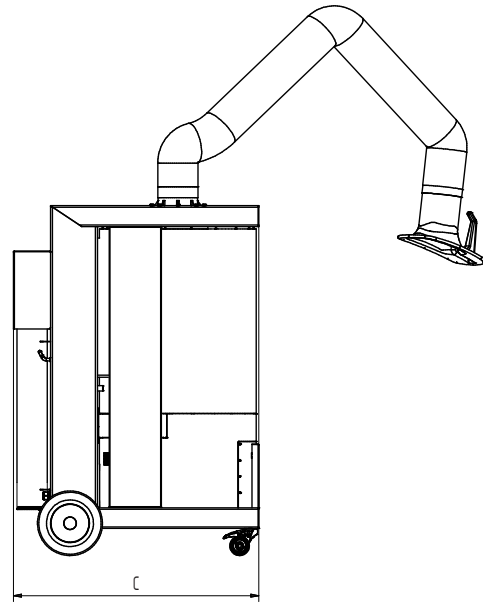
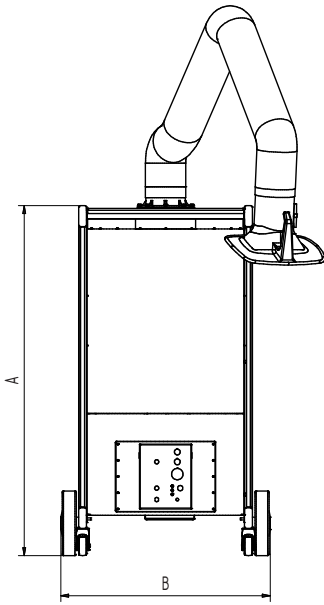

Technical Data

Dimensions

A	1350 mm
B	810 mm
C	940 mm
D	665 mm
E	798 mm
F	150 mm
G	360 mm
H	295 mm